



**PEUGEOT**  
MOTORCYCLES

**PM-01**

**PM-02**

**PM-03**

**Livret de bienvenue  
& d'entretien**

Welcome  
& maintenance booklet





**Bienvenue**

**FR**

**Welcome**

**GB**

**Herzlich willkommen**

**DE**

**Benvenuto**

**IT**

**Bienvenidos**

**ES**

**Welkom**

**NL**

**Καλώς ήρθατε**

**GR**

**Välkommen**

**SE**

**Bem-vindo**

**PT**

**Tervetuloa**

**FI**



**Velkommen**

**DK**





## TABLE OF CONTENTS

Pre-delivery inspection.....	1
Information.....	2
Diagnostic and Personal data.....	2
Manufacturer's warranty.....	3
Important.....	6
Products to use.....	6
Maintenance advice.....	6
Cleaning the vehicle.....	6
Environment / Recyclable.....	7
Extended periods of immobilisation and storage.....	7
Quick-start guide.....	8
Starting and driving.....	8
Controls.....	9
Instruments.....	11
Digital display.....	11
Indicator lights and warning lights.....	11
Resetting the trip recorder.....	12
Equipments.....	13
Accessory socket (USB).....	13
Lateral stand.....	13
Ignition cut-out.....	13
Advice.....	14
Fuel supply  .....	14
Opening the fuel tank cap.....	14
Closing the fuel tank cap.....	14
Filling.....	14
Checking the engine oil level  .....	14
Cleaning and greasing the chain.....	15
Check the drive belt tension  .....	15
Chain tension adjustment.....	15
Periodic servicing.....	16
Service schedule.....	17

**GB**

## MEMORANDUM

Name: .....  
.....  
First name: .....  
.....  
Address: .....  
.....  
Post code: .....  
.....  
Town: .....  
.....  
Telephone number: .....  
.....  
Model: .....  
.....  
Colour: .....  
.....  
Engine no.: .....  
.....

## PRE-DELIVERY INSPECTION

VIN: VGA

The dealer must carry out the pre-delivery inspection and supply the preparation sheet for the delivered vehicle.

### Inspection on delivery

Customer signature

I have inspected the appearance of the vehicle and signed the pre-delivery preparation sheet for my vehicle, I did not notice any anomaly. I have been informed that it is important to read the user manual and maintenance book.

Date:

Customer signature:

Dealer signature

I confirm that the vehicle identified above has undergone preparation and a pre-delivery inspection as specified by PEUGEOT MOTOCYCLES. I have supplied the customer with the user manual and maintenance book. I have explained how to operate the machine's controls and emphasised that it is important to consult the user manual and PEUGEOT MOTOCYCLES warranty conditions.

Date:

Dealer signature:



## INFORMATION

You have just bought a Peugeot vehicle. We would like to thank you for purchasing one of our products.

Your vehicle is built to last but this does not mean that it does not require a minimum amount of maintenance.

Your authorised dealer is familiar with all the vehicle's characteristics and has genuine spare parts and specific tools. He can advise you and service your vehicle in the best conditions according to the established service schedule to ensure that you can enjoy driving it in complete safety.

This manual must be considered as an integral part of the vehicle and must remain with it even if the vehicle is sold on.

It also describes a selection of your vehicle's most common functions.

However, we advise you to read the entire user manual, which is available in digital format at the following address:

<https://www.peugeot-motocycles.fr/documentation>

Scan this QR code for direct access:









In particular, you will find the safety instructions, warnings, important notes and comments in it.

PEUGEOT MOTOCYCLES is constantly improving its vehicles. It therefore reserves the right to remove, modify or add any reference mentioned

The only authentic documents are those available online at the above address.

## The following symbols mean:

	You are advised to read the full version of the user manual.
	Operation that can be dangerous for people.
	Operation that can be hazardous to the vehicle.
	Gives key information concerning operation of the vehicle.
	An asterisk indicates equipment depending on the version.
	The product pollutes. Do not dispose of it in the environment.

## DIAGNOSTIC AND PERSONAL DATA

When diagnostic tools are connected to your vehicle, they collect data. This data includes your vehicle's identification number (VIN).

For further information on your rights or the way PEUGEOT MOTOCYCLES processes data, please refer to our privacy policy at the following address:

<https://peugeot-motocycles.com/fr/mentions-legales/>

Or contact us at:

<mailto:dpo@peugeotmotocycles.com>

## MANUFACTURER'S WARRANTY

(March 2022 edition)

The manufacturer of your vehicle, PEUGEOT MOTOCYCLES, which has its head office at rue du 17 novembre - 25350 Mandeure (France), hereinafter PEUGEOT MOTOCYCLES, offers you a commercial warranty on your new combustion engine or electric vehicle against any material or construction defects.

These manufacturer warranty terms are also available on the website.

<https://www.peugeot-motocycles.fr/documentation>

### Duration of the warranty

Unless specific contrary provisions have been brought to your attention (warranty extension, fleet agreement, etc.), PEUGEOT MOTOCYCLES grants your vehicle a manufacturer's warranty for a period of:

- 24 months for private use, unlimited mileage;
- 24 months for professional use, limited to 20 000 km (<50cc, cat. L1e & L2e) or 30 000 km (>50cc, cat. L3e & L5e).



The term 'trader' is defined as "any public or private natural or legal person acting for purposes relating to their trading, business, craft, professional or agricultural activity, even when they act in the name or on behalf of another trader".

This warranty starts from the first time the vehicle is registered and applies to your vehicle with the exception of:

- The electric vehicle traction battery for which the current warranty is 24 months or 20 000 km, whichever is reached first, subject to the maintenance charges having been done regularly in accordance with the instructions in the PEUGEOT MOTOCYCLES maintenance manual;
- The electric vehicle traction battery for which the stated nominal capacity has declined by less than or equal to 25%, measured by a PEUGEOT MOTOCYCLES network technician during the warranty period. Due to the inherent chemistry of the battery, a decline in battery capacity (and therefore the vehicle's autonomy) may be observed over time, as the vehicle is used and according to the storage conditions;
- The combustion engine vehicle battery for which this warranty is six months subject to a minimum mileage of 200 km per month;
- The stand and the saddle, for which the warranty period is six months.

### Scope of the manufacturer's warranty

With the exception of the restrictions stated below, this contractual warranty covers the repair or replacement of parts found to be faulty by PEUGEOT MOTOCYCLES or its representative and any ensuing labour costs.

#### It should be noted that:

- The repair or replacement of parts under this manufacturer's warranty does not extend the duration thereof. The warranty covering replacement parts fitted to your vehicle expires on the same date as your vehicle warranty;
- The faulty parts replaced under the warranty will be kept and become the property of PEUGEOT MOTOCYCLES.

## Conditions of application of the commercial warranty

For optimal cover for work to be carried out on your vehicle under this commercial warranty, PEUGEOT MOTOCYCLES recommends that you exclusively entrust said work to a workshop within the authorised network.

If your vehicle is sold on, its successive owners shall benefit from the warranty until its date of expiry on condition that the application conditions of the warranty have been satisfied by each of them. For this purpose, you undertake to transmit the warranty application terms to the buyer of your vehicle, along with evidence of maintenance operations performed.



**The warranty applies on condition that:**

- The first "warranty" service has been carried out and the vehicle has been regularly serviced in line with the instructions of the PEUGEOT MOTOCYCLES maintenance manual, and you can provide proof of this (service monitoring sheet, invoices, etc.). A tolerance of 100 km (or 1 month) for the annual maintenance) is permitted in relation to the mileage specified in the maintenance schedule;
- The enhanced maintenance schedule is applied for professional use and, where necessary, for private use;
- Original parts have not been replaced with other components that have not been approved by PEUGEOT MOTOCYCLES and/or the assembly of which does not comply with good practices or the recommendations of PEUGEOT MOTOCYCLES (including, but not limited to, exhaust pipe, cylinder, piston, spark plug and the intake silencer on combustion vehicles, fuses, traction battery modules and the traction battery charger on electric vehicles, etc.);
- The vehicle has not been modified, transformed or equipped with accessories that have not been approved by PEUGEOT MOTOCYCLES (including, but not limited to, additional charger for electric vehicles, alarms, radio, headlights, luggage carriers, boosters, etc.);
- The vehicle has not been used for sports competitions;

**The warranty does not cover:**

- Maintenance operations (such as, but not limited to: oil change, lubrication, adjustment, cleaning, tensioning, etc.) and servicing listed in the PEUGEOT MOTOCYCLES service schedule and required for your vehicle to operate properly;
- The replacement of parts subject to normal wear linked to use of the vehicle, its mileage, its geographical and climatic environment and their non-reusable fastening parts (such as, but not limited to: self-locking nuts, etc.), if this replacement is not due to a manufacturing defect. This includes but is not limited to the following parts:
  - Drive pulley and driven pulley and belt, clutch, rollers, mobile flange, guides, chain, pinion, rear cog;
  - Bearings (wheels, rods, steering, engine, etc.);
  - Bulb, fuse, tyre, brake linings and pads, brake disc, cables and cable controls, spark plug and spark suppressor;
  - Shock absorbers (hydraulic, gas, single spring, elastomer), air filter, entire intake silencer, fuel filter, oil filter, cylinder, piston and piston segments;
  - Exhaust on combustion engine (except unwelded internal elements);
  - Liquids and products (grease, hydraulic fluid, brake fluid, gearbox oil, engine oil and coolant, etc.);
- Repairs resulting from the use of fuels, lubricants or grease other than those recommended by PEUGEOT MOTOCYCLES;
- Repairs resulting from negligence, abnormal use, driving on an impassable or damaged road, failure to follow the advice given in the PEUGEOT MOTOCYCLES service schedule or the user manual, overloading, even temporary, or the driver's lack of experience;

- Repairs due to an accident, theft, fire or natural causes (including, but not limited to hail, flooding, etc.);
- Repairs resulting from lack of vehicle cleanliness;
- Repairs resulting from long storage periods under unsuitable conditions;
- Corrosion or surface oxidation on the chassis, the screws, and, more generally, on all other metal parts, whether treated or not on combustion or electric vehicles (however, pitting corrosion is covered for a period of 24 months);
- The meter or optics for which the presence of steam does not alter information readability or lighting efficiency;
- Noises and vibrations which have no influence on the reliability, safety and road behaviour of the vehicle;
- Any other expenses not specifically included in this warranty or the legal compliance warranty or the legal warranty against hidden defects, such as, but not limited to: costs due to the vehicle being immobilised, loss of use or business, etc.

**Geographical scope of application**

The warranty is applicable in the countries or territories where the vehicle is marketed by the approved PEUGEOT MOTOCYCLES network (in particular, France, Germany, Italy, Spain) a list of which can be consulted on the manufacturer's website:

<http://www.peugeot-motocycles.com>

The vehicle is intended exclusively for sale and use in the above-mentioned countries and territories excluding all other countries or territories, where the applicable standards may be different to those in the above-mentioned countries and territories, such as, but not limited to, the United States of America, etc. Use of the vehicle in these excluded countries or territories is under the user's entire responsibility and excludes the application of this warranty as well as the vehicle manufacturer's responsibility for any reason whatsoever.

In some countries, especially in European Union Member States, the consumer has rights under the applicable national legislation. These rights are not affected by the warranty as defined above.



## IMPORTANT

### Products to use

Fuel	Exclusively: Unleaded E5 or E10
	
4 stroke engine oil	SAE 15W50 100% synthetic Minimum grade API SN/SM/SL JASO : MA2 T903
Fork oil	Hydraulic oil SAE10W
Grease	High-temperature grease Multi-use grease
Drive chain	Cleaner for MOTUL transmission chain Grease for MOTUL MC CARE C4 chain compatible with O-Ring, X-Ring, Z- Ring chains
Brake fluid	Brake fluid DOT5.1
Coolant	Coolant: MOTUL MOTOCOOL EXPERT -37°C Anti-corrosion and anti-freeze Protection: 37°C/-35°F Nitrite free / Amine free / Phosphate free

# MOTUL

## Maintenance advice

Ensure that the servicing schedule for your vehicle is strictly followed to maintain your contractual warranty rights.  
A table of inspections for the maintenance schedule is inserted into the maintenance booklet. The registered dealer must add his stamp, the date of servicing and the number of kilometres the vehicle has covered.

In order to maintain maximum safety and reliability of your vehicle, you are advised to have maintenance and repairs carried out by a registered dealer who has the necessary technical training, specific tools and spare parts.

After an accident, it is recommended to have the vehicle inspected and repaired by a registered dealer.

## Cleaning the vehicle



The bodywork is made of plastic parts that can be painted or are shiny. Do not use solvents or cleaning products that are too corrosive.



Do not use high pressure cleaners which may cause water to infiltrate the following parts: seals, bearings and hinges, electrical components such as connectors, contactors and lighting.

Wash the bodywork with soapy water and rinse with generous amounts of clear water.

The vehicle can be dried with a chamois leather.  
After washing the vehicle, brake several times at low speed to dry out the brakes.



The vehicle should be washed in a place equipped for wastewater collection.

Certain silicon-based products can alter the quality of the paintwork.

In case of need or doubt, a registered dealer can advise you on using cleaning products or restoring scratched bodywork.

### Environment / Recyclable

Worn parts replaced during routine maintenance (mechanical parts, battery, etc.) must be disposed of with specialised bodies.

At the end of its life, the vehicle must be taken to an authorised centre for recycling.

In all cases, comply with the local laws.



Batteries contain harmful substances. They must be disposed of according to the legal requirements and must under no circumstances be thrown away in the household waste.

### Extended periods of immobilisation and storage

If the vehicle has to be immobilised for more than 1 months, you are advised to carry out the following operations:

#### Battery



If the vehicle is not used for an extended period, the battery will slowly discharge naturally or due to its electronics or certain accessories and must thus be regularly charged.

- Charge the battery to 100% beforehand (The battery's maximum charging current is equal to 1 tenth of its capacity).
- Use a maintenance charger or charge monthly.
- Before restarting, the battery must be charged to 100%.



If these recommendations are not followed, the battery may go into deep discharge. In this case the manufacturer's warranty will be void.

#### Machine

- Empty the fuel tank to avoid fuel build-ups.
- Spray a lubricant onto the metal parts of the vehicle to avoid oxidation.
- Store the vehicle in a dry place.

#### Re-starting your vehicle

You are advised to have the vehicle checked over by a registered dealer if it has been immobilized for an extended period.

## QUICK-START GUIDE

### Starting and driving

GB

#### Key-operated ignition switch functions

2 keys are delivered with the vehicle.

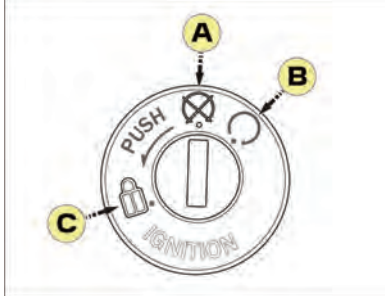

- A. Engine off position
- B. On position
- C. Steering unlocked

#### Starting the engine

✓ The engine may only be started if the gear selector is in the neutral position: (N).

For increased safety, sit on the vehicle before starting the engine.

- Fold back the side stand.
- Turn the ignition key to "ON".
- Make sure that the gear selector is in neutral (N).
- Keep the throttle hand grip closed.
- Press the starter button. Do not press the starter for more than 5 seconds.
- Release the starter button as soon as the engine starts.



If the engine does not start, release the starter button, wait a few seconds and try again. Each attempt to start the engine should be as short as possible to save the battery.

Do not press the starter for more than 5 seconds.

#### Driving

##### Starting off

After having started up the engine:

- To declutch, pull the left clutch lever towards the handlebar.
- Engage first gear by pushing the gear selector downwards with your left foot.
- Accelerate without excess to increase the engine speed.
- Gradually release the clutch lever while opening the throttle further until the vehicle starts.
- Shift the other gears by closing the throttle each time, declutching and turning the gear selector upwards.

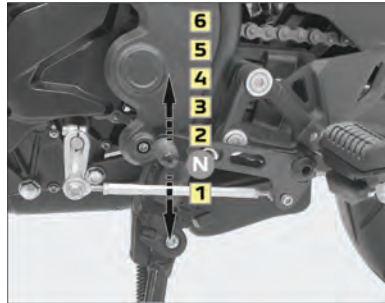

##### Accelerating and decelerating

Shift gears up or down to allow the engine to run at a normal speed corresponding to the traffic conditions.

To adjust speed, open or close the throttle.

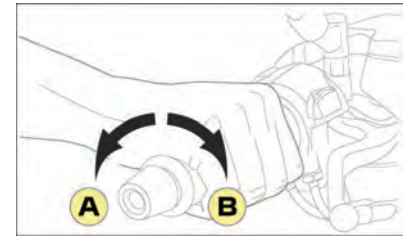

To accelerate, turn the throttle towards (A). To slow down, turn the throttle towards (B).

##### Braking

Vehicle fitted with an ABS braking system.

- The anti-lock braking system (ABS) is designed to prevent the wheels from locking up during braking.
- The ABS system enables the rider to retain control of the vehicle when braking in slippery conditions.

##### Use of the brakes

- Close the throttle.
- Activate the brake system by gradually increasing the pressure.
- To be more effective, use the front and rear brake at the same time and in the same way.

✓ The ABS system is not active when the vehicle speed is less than or equal to approximately 5 km/h.  
The ABS system does not work if the battery is flat.

##### Stopping the vehicle and parking

The engine should always be switched off when the vehicle has come to a halt, and the engine is ticking over.

- Make sure that the gear selector is in neutral (N).
- Turn the ignition key to "OFF" to stop the engine.
- Dismount from the vehicle.
- Place the vehicle on its side stand on flat ground.
- Turn the handlebar towards the left and lock the steering.
- Remove the ignition key.

When stopping on a steep slope, you are advised to.



The steering must be locked every time you park.

### Controls



Refer to the online user manual for further information.

#### Left controls

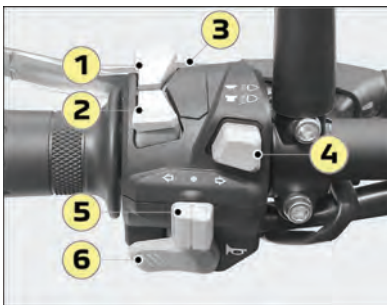

#### 1. "ENTER" control.

This control enables:

- Access to the settings and personalisation menu on the digital display (Short press).
- Confirmation of a choice (Short press).



Refer to the online user manual for further information.

#### 2. "SELECT" control.

This control enables:

- Navigation within the menus (Short press).





Refer to the online user manual for further information.

#### 3. Light flashing button.

- Press this button to flash the headlights.

#### 4. Dipped light switch / High beam.

This control only operates if the lighting switch on the right handlebar set to position : .

- Button released: Dip beam .
- Button pressed: High beam .

#### 5. Indicator light switch.

To indicate a change of direction, press the switch:

- Either to the right.
- Or to the left.



To stop the indicators flashing, press the switch.

#### 6. Horn switch.

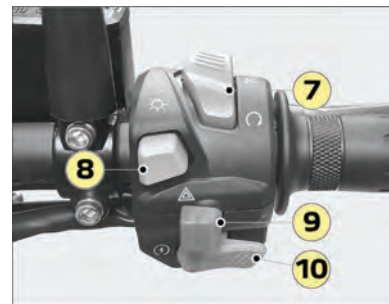
#### Right controls



#### 7. Emergency stop button.

-  Set the button to this position in case of emergency to stop the engine.
-  Set the button to this position before starting the engine.

#### 8. Lighting switch / Daytime lights (DRL Daytime Running Light).

- Button released: Daytime lights.
- Button pressed: Sidelight.

The headlights light up when the engine is started. They go out when the ignition is switched off after the vehicle is at a complete standstill.

#### 9. Hazard warning light switch.

The hazard warning lights only work with the ignition key in the "ON" position.



To prevent the battery from going flat, do not use the hazard lights for a long period of time with the engine switched off.

#### 10. Starter switch.

Press this button to start the engine.

### Clutch lever

The clutch lever is found on the left handle of the handlebar. To disengage the clutch, pull the lever towards the handle. To put into gear, release the lever. Smooth operation is achieved by pulling the lever quickly and releasing it slowly.

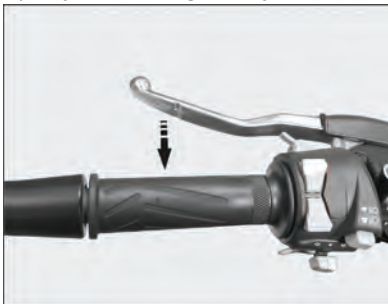

The clutch lever is equipped with a clutch switch, which is a component of the ignition circuit cut-off. (See chapter: [Ignition cut-out](#) page 13 ).

### Speed selector

The selector is located on the left side of the motorcycle and is used together with the clutch lever when changing between the 6 constant mesh gears in the gearbox.

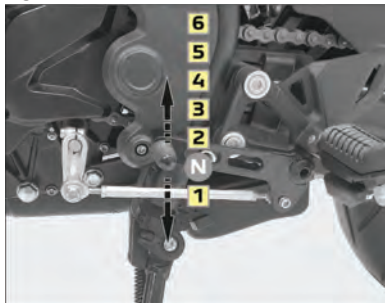

Always move down the gears one at a time and at the correct vehicle speed to prevent the engine from over-revving and the rear wheel from locking up.

### Front brake lever

The brake lever is found on the right handle of the handlebar. To activate the front brake, pull the lever towards the throttle.

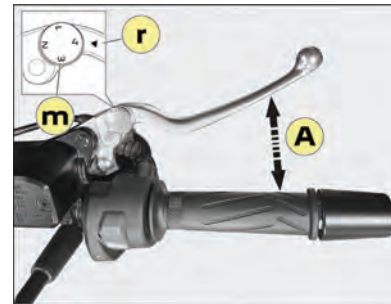

The front brake lever is equipped with a position adjustment wheel.

To adjust the distance (A) between the lever and the handle, turn the adjustment knob and push the lever away from the handle.

Ensure the position selected on the knob (m) and the marking on the lever (r) are properly aligned.

- 1 position: Near.
- 4 position: Far.

## Rear brake pedal

The brake pedal is found on the right side of the motorcycle. Press the brake pedal to activate the rear brake.



## INSTRUMENTS

### Digital display



- 1 - Fuel gauge.
- 2 - Maintenance indicator.
- 3 - Clock.
- 4 - "Bluetooth" connection.
- 5 - Smartphone connection.
- 6 - Incoming or outgoing call number display.
- 7 - Revolution counter.
- 8 - Battery voltage.
- 9 - Engine temperature gauge.
- 10 - Tripmeter (TRIP 1 / TRIP 2).
- 11 - Digital speedometer (km/h or mph).
- 12 - Milometer.
- 13 - Correct gear indicator.



Refer to the online user manual for further information.

## Indicator lights and warning lights

The warning lights inform the driver of the start-up of a system or appearance of a malfunction.

- On ignition, some warning lights are displayed for a few seconds.
- Once the engine is started, these warning lights will disappear.

**If they remain on, use the table to check the relevant warning light before driving off.**



✓ The ABS system ON warning light disappears when the vehicle starts to move.

- Emissions control system failure warning light / Engine self-diagnostic (MIL).
  - Wheel anti-lock indicator light (ABS).
- These indicators light up in two ways (steady or flashing).



In all cases, you are advised to have the vehicle checked by an approved dealer.



Refer to the online user manual for further information.

## Resetting the trip recorder

Short press on the "ENTER" button to confirm a choice.

Short press on the "SELECT" button to scroll through the menus.

- Turn on the ignition.
- Short press on the "ENTER" button to access a menu.
- Select the "TRIP" line and confirm.



- Select the trip recorder to be reset and confirm.



- Exit the menu.
- Turn off the ignition.

## EQUIPMENTS



The user manual describes other equipment.

### Accessory socket (USB)

Installed at handlebar level, an accessories socket, which is powered when the ignition is switched on, enables you to connect portable equipment (Telephone number, GPS, ... ) (2 A maximum).

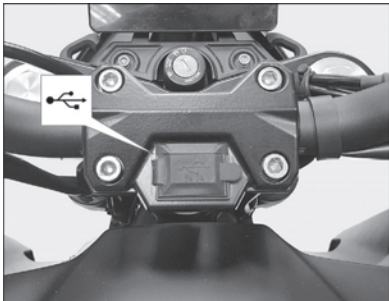

The equipment can recharge automatically during use.



Always replace the cap after use to prevent moisture from entering the socket.

## Lateral stand

The lateral kickstand is fitted with an ignition cut-out which prevents the engine from being started while the stand is down.

This system reminds the driver to lift the stand before starting the engine (See chapter: [Ignition cut-out](#) page 13 ).



If the engine starts with the kickstand down, it is essential to have the circuit checked by an approved dealer.

Do not start to move off if the kickstand is still down or is not raised properly. It could touch the ground and distract the rider, who could lose control of the vehicle.

The ignition cut-off system reminds the rider to raise the kickstand before moving off. You are advised to check this system regularly and have it repaired by an approved dealer should a malfunction occur.

### Ignition cut-out

The ignition cut-out system, which comprises the side stand, clutch and neutral switches, performs the following functions:

- It prevents the engine from starting when a gear is engaged and the side stand is raised but the clutch lever is not activated.
- It prevents the engine from starting when a gear is engaged and the clutch lever is pulled in but the side stand has not been raised.
- It cuts off the engine when a gear is engaged and the side stand is down.

**Regularly check the operation of the ignition circuit cut-out by performing the following procedure.**

## ADVICE

### Fuel supply



The engine must be switched off in order to fill the fuel tank in complete safety.

GB

A label affixed near the fuel cap reminds you of the type of fuel to use.



E5



Bleifreies Benzin  
Unleaded fuel only  
Carburant sans plomb  
Gasolina sin plomo  
Bezolovnatý benzin  
Endast blyfri bensin  
RON/ROZ min. 95

E10

Any fuel containing up to 10% ethanol can be used (E5, E10).

An ethanol content of more than 10% by volume is not permitted. E85 must not be used.



## Opening the fuel tank cap

- Lift the lock cover of the tank cap.
- Insert the key into the lock, then turn it 1/4 turn to the right.
- The tank cap opens.



## Closing the fuel tank cap

- Insert the key into the lock.
- Turn the key 1/4 turn to the right.
- Push on the cap then return the key to its starting position by turning it to the left.

## Filling

- Insert the petrol pump nozzle into the filling orifice. Make sure the nozzle is correctly inserted into the filling pipe.

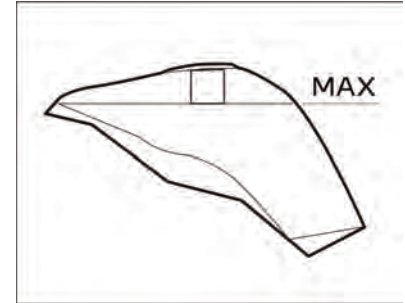

- Fill the tank to the lower end of the filler tube and not beyond it.



Do not fill the fuel tank to excess: The fuel may expand due to the engine heat or heat from the sun and overflow.

## Checking the engine oil level



Check the oil level every 1000 km / 600 Mi or before a long journey.

### Level check.

- Place the vehicle on a level surface.
- Hold the vehicle so that it is upright.
- Start the engine, let it run for a few minutes and then stop it.
- After switching off the engine, wait for 3 minutes to allow the engine oil time to return to the oil sump.
- Check the coolant level through the oil-contect window.
- The oil level shall be between the minimum and maximum level marks without exceeding the latter.
- If required, top up the oil to the maximum level.

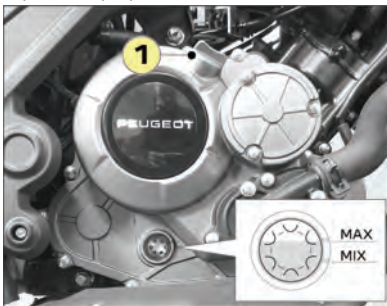

1. Engine oil filler cap.



Too much oil will noticeably restrict the vehicle's performance.

### Cleaning and greasing the chain



This vehicle is equipped with a ring chain.

You are advised to lubricate the transmission chain at regular intervals (Every 500 km / 300 mi). Lubricate the transmission chain using a lubricant specifically for ring chains.



Do not clean the transmission chain using a high-pressure jet or an inappropriate solvent as this could damage the chain. After washing the vehicle, wipe down the transmission chain properly and lubricate it. Clean the transmission chain using petroleum and a soft bristle brush or a suitable aerosol cleaner.

### Check the drive belt tension

Check the tension of the chain every time before you depart.



The vehicle must be on its stand, with the gearbox in neutral position.

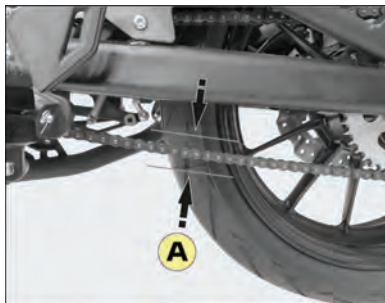

- Measure the tension of the chain as shown.

### Chain tension

A = 28 - 35 mm

Adjust the tension of the transmission chain if it is incorrect (See chapter: [Chain tension adjustment](#) page 15).

### Chain tension adjustment

- The vehicle must be on its stand, with the gearbox in neutral position.
- Loosen the wheel axle and the locknuts of the tensioners.
- Do the same on each of the setting nuts so as to obtain a chain variation of 28-35 mm. Use the centring graduations for precise adjustment.
- Check the correct chain alignment between the gearbox drive sprocket and the rear sprocket.
- Tighten the wheel axle (Tightening torque: 100 Nm).
- Tighten the locknuts of the tensioners (Tightening torque: 20 Nm).
- Check the belt tension.

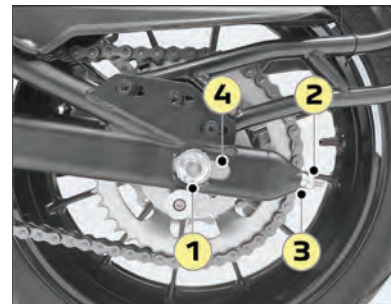

1. Rear wheel spindle.
2. Locknut.
3. Setting nut.
4. Chain tensioner / Centring graduations.



An over-tensioned chain leads to premature wear of the gearbox output shaft bearing, the rear wheel bearings, the chain and the sprockets.

## PERIODIC SERVICING

### Special important points:

- Compliance with the servicing schedule in light of the conditions of use will help keep your vehicle running smoothly over time and preserve its qualities, while being covered by the warranty. We recommend that you entrust these operations to an authorised Peugeot Motorcycles dealer who has been trained by the manufacturer and has suitable tools.
- There is no need for an annual test if a periodic test has been conducted during the year.
- From 25000 km (15600 mi), servicing must be performed by repeating operations from 5000 km (3100 mi).
- Clean or replace the air filter (engine/transmission) more often if the vehicle is used in particularly dusty or humid areas.

### Heavy duty servicing / Harsh conditions of use:

Maintenance of affected components should be carried out more regularly if the vehicle is used under any of the following conditions:

Humid, dusty, high heat area, predominantly urban use, at temperatures frequently dropping below -5°C, Repeated short or door-to-door trips with a cold engine at a low temperature, etc.

Vehicles used for commercial purposes (home deliveries, couriers, etc.) should, in particular, be subject to heavy duty servicing:

Under harsh conditions of use:

- The maintenance frequency can be reduced (Depending on model: mileages marked with an asterisk in the periodic maintenance table).
- The replacement frequency for certain components is reduced (Refer to the periodic maintenance table).

### Care / Cleanliness:

In light of the design and aesthetic appeal of a two-wheeled vehicle, numerous components are exposed to the elements. This vulnerability may

result in functional or cosmetic damage (corrosion, etc.), even on high-quality parts. This is why proper regular servicing helps not only preserve its appearance, smooth running and your enjoyment; it is also essential to maintain your Warranty rights.

## SERVICE SCHEDULE

Servicing must be performed by a PEUGEOT MOTOCYCLES registered representative.







Operations to be carried out	1000 km 600 mi or 1 months	5000 km 3100 mi	10000 km 6200 mi	15000 km 9400 mi	20000 km 12400 mi	Annual maintenance
<b>Engine</b>						
Engine oil	R	R	R	R	R	R
Oil filter	R	At each engine oil change				R
Valve clearances	I	I Every 10000 km				
Spark plug			R		R	
Intake air filter	R Every 5000 km (2500 km if harsh use servicing)					
Petrol filter					R	
Petrol pipe: No leaks or cracks	I	I	I	I	R	I
Coolant level	I	I	I	I	I	I
Cooling system radiator	I	I	I	I	I	I
Coolant	R Once every 3 years					
Canister unit, canister valves and hoses	I	I	I	I	I	I
<p style="text-align: center;"><b>I: Inspect, clean, adjust, replace if necessary.</b>      <b>C: Clean, replace if necessary.</b>  <b>R: Change.</b>      <b>L: Lubricate, oil</b></p>						



Operations to be carried out	1000 km 600 mi or 1 months	5000 km 3100 mi	10000 km 6200 mi	15000 km 9400 mi	20000 km 12400 mi	Annual maintenance
<b>Cycle part</b>						
Drive chain: Lubrication	L Every 500 km					L
Drive chain: Tension	I Every 1000 km					I
Sprocket / Ring gear / Chain tensioner	I	I	I	I	I	I
Steering: No sticking point / No play	I	I	I	I	I	
Wheels: Condition and runout / No play	I	I	I	I	I	
Tyres: No cracks, wear and pressure	I	I	I	I	I	I
Fork / Front suspension: Condition, operation and no leakage	I	I	I	I	I	I
Fork oil					R	
Rear suspension: Condition, operation and no leakage	I	I	I	I	I	I
Swingarm: No play	I	I	I	I	I	
Throttle control: Operation, play and lubrication	I + L	I + L	I + L	I + L	I + L	I
Clutch control: Operation, play and lubrication	I + L	I + L	I + L	I + L	I + L	I
Moving parts and cables	L	L	L	L	L	I
Kickstands: Operation and lubrication	I + L	I + L	I + L	I + L	I + L	I
Tightness of nuts and bolts	I	I	I	I	I	
<b>I: Inspect, clean, adjust, replace if necessary. R: Change.</b>			<b>C: Clean, replace if necessary. L: Lubricate, oil</b>			

Operations to be carried out	1000 km 600 mi or 1 months	5000 km 3100 mi	10000 km 6200 mi	15000 km 9400 mi	20000 km 12400 mi	Annual maintenance
<b>Braking system</b>						
Brake fluid level / No leakage	I	I	I	I	I	I
Brake fluid	R Once every 2 years					
Brake calipers: Cleanliness, guide pins, Functioning	I + L	I + L	I + L	I + L	I + L	
Brake pad wear	I	I	I	I	I	I
Brake disk wear	I	I	I	I	I	I
Brake hoses: No leaks or cracks	I	I	I	I	I	I
Brake levers		L	L	L	L	
<b>Electrical equipment</b>						
Lighting and signalling	I	I	I	I	I	I
Headlight height adjustment	I	I	I	I	I	I
Brake light switches	I	I	I	I	I	I
Ignition cut-out	I	I	I	I	I	I
Battery: Charge level and no leakage	I	I	I	I	I	I
<b>Miscellaneous</b>						
Processors: Reading of fault codes and update	I	I	I	I	I	I
Overall operation: Road test	I	I	I	I	I	I
<p style="text-align: center;"><b>I: Inspect, clean, adjust, replace if necessary.</b>      <b>C: Clean, replace if necessary.</b>  <b>R: Change.</b>      <b>L: Lubricate, oil</b></p>						
<b>Servicing time in tenths of an hour (0.5 h = 30 mn)</b>						
Reception and Treatment	0.1	0.1	0.1	0.1	0.1	0.1
PM-01	1	2.5	2.5	2.5	3.5	1
PM-02 / PM-03	1	1.5	3.5	1.5	4.5	1
<b>Maintenance times are indicative. They do not take into account either the replacement of worn parts or the condition of the vehicle.</b>						

**GB**

<p>_____ km</p> <p>_____ <i>mi</i></p> <p> _____ / _____ / _____</p>	<p>_____ km</p> <p>_____ <i>mi</i></p> <p> _____ / _____ / _____</p>	<p>_____ km</p> <p>_____ <i>mi</i></p> <p> _____ / _____ / _____</p>
<p>_____ km</p> <p>_____ <i>mi</i></p> <p> _____ / _____ / _____</p>	<p>_____ km</p> <p>_____ <i>mi</i></p> <p> _____ / _____ / _____</p>	<p>_____ km</p> <p>_____ <i>mi</i></p> <p> _____ / _____ / _____</p>
<p>_____ km</p> <p>_____ <i>mi</i></p> <p> _____ / _____ / _____</p>	<p>_____ km</p> <p>_____ <i>mi</i></p> <p> _____ / _____ / _____</p>	<p>_____ km</p> <p>_____ <i>mi</i></p> <p> _____ / _____ / _____</p>

FR

GB

DE

IT

ES

NL

GR

SE

PT

FI

DK

FR

GB

DE

IT

ES

NL

GR

SE

PT

FI

DK

\_\_\_\_\_ km

\_\_\_\_\_ *mi*



----- / ----- /-----

\_\_\_\_\_ km

\_\_\_\_\_ *mi*



----- / ----- /-----

\_\_\_\_\_ km

\_\_\_\_\_ *mi*



----- / ----- /-----

\_\_\_\_\_ km

\_\_\_\_\_ *mi*



----- / ----- /-----

\_\_\_\_\_ km

\_\_\_\_\_ *mi*



----- / ----- /-----

\_\_\_\_\_ km

\_\_\_\_\_ *mi*



----- / ----- /-----

\_\_\_\_\_ km

\_\_\_\_\_ *mi*



----- / ----- /-----

\_\_\_\_\_ km

\_\_\_\_\_ *mi*











----- / ----- /-----

\_\_\_\_\_ km

\_\_\_\_\_ *mi*



----- / ----- /-----

<p>----- km</p> <p>----- mi</p>	
<p>----- km</p> <p>----- mi</p>	
<p>----- km</p> <p>----- mi</p>	
<p>----- km</p> <p>----- mi</p>	
<p>----- km</p> <p>----- mi</p>	
<p>----- km</p> <p>----- mi</p>	
<p>----- km</p> <p>----- mi</p>	
<p>----- km</p> <p>----- mi</p>	
<p>----- km</p> <p>----- mi</p>	

FR

GB

DE

IT

ES

NL

GR

SE

PT

FI

DK

FR

\_\_\_\_\_ km



\_\_\_\_\_ mi

GB

\_\_\_\_\_ km



\_\_\_\_\_ mi

DE

\_\_\_\_\_ km



\_\_\_\_\_ mi

IT

\_\_\_\_\_ km



\_\_\_\_\_ mi

ES

\_\_\_\_\_ km



\_\_\_\_\_ mi

NL

\_\_\_\_\_ km



\_\_\_\_\_ mi

GR

\_\_\_\_\_ km



\_\_\_\_\_ mi

SE

\_\_\_\_\_ km



\_\_\_\_\_ mi

PT

\_\_\_\_\_ km



\_\_\_\_\_ mi

FI

DK



Peugeot Motocycles recommends



Quality management system certified ISO  
9001 by UTAC



**Peugeot Motocycles SA**  
**Rue du 17 Novembre**  
**F-25350 Mandeuire**

Tél. +33(0)3 81 36 80 00

RCS Belfort B 875 550 667

[www.peugeot-motocycles.fr](http://www.peugeot-motocycles.fr)  
[www.peugeot-motocycles.com](http://www.peugeot-motocycles.com)

**0 800 007 216**

Service & appel  
gratuits

Dans un souci constant d'amélioration Peugeot Motocycles se réserve le droit de supprimer, modifier ou ajouter toutes références citées.  
DQ/APV du 02/2024 (photos non contractuelles).





# PEUGEOT MOTOCYCLES



Guide d'utilisation en ligne  
Online user's guide