



**PEUGEOT**  
MOTORCYCLES



## **PEUGEOT TWEET**

Livret de bienvenue  
& d'entretien

Welcome  
& maintenance booklet



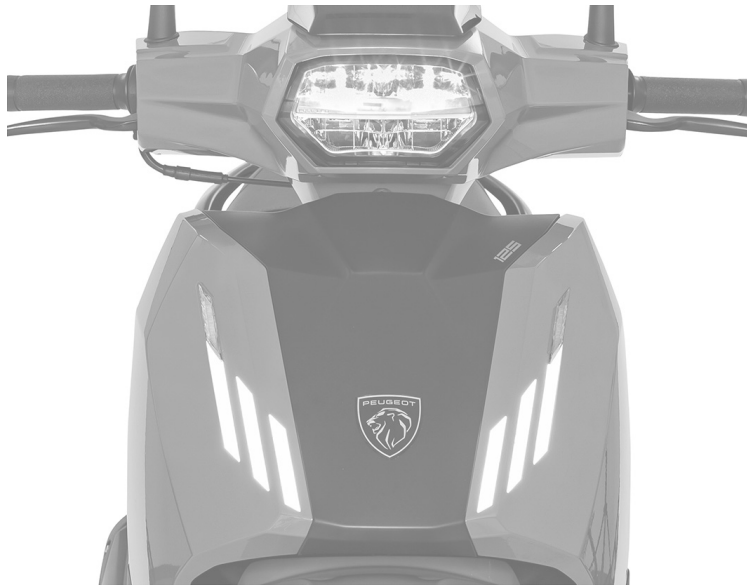

**Bienvenue**

**FR**

**Welcome**

**GB**

**Herzlich willkommen**

**DE**

**Benvenuto**

**IT**

**Bienvenidos**

**ES**

**Welkom**

**NL**

**Καλώς ήρθατε**

**GR**

**Välkommen**

**SE**

**Bem-vindo**

**PT**

**Tervetuloa**

**FI**



**Velkommen**

**DK**





## TABLE OF CONTENTS

Pre-delivery inspection.....	1
Information.....	2
Diagnostic and Personal data.....	2
Manufacturer's warranty.....	3
Important.....	6
Products to use.....	6
Maintenance advice.....	7
Cleaning the vehicle.....	7
Environment / Recyclable.....	7
Extended periods of immobilisation and storage.....	8
Quick-start guide.....	9
Starting and driving.....	9
Braking  .....	9
Stopping the vehicle and parking  .....	9
Controls.....	10
Instruments.....	11
Digital display.....	11
Warning lights.....	11
Equipments.....	12
Adjustment of damper settings *.....	12
Utility hanger.....	12
Lateral stand *.....	12
Advice.....	12
Fuel supply.....	12
Checking the engine oil level  .....	13
Periodic servicing.....	14
Service schedule TWEET 50 CC.....	15
Service schedule TWEET 125 / 200 CC.....	18

GB

## MEMORANDUM

Name: .....  
.....  
First name: .....  
.....  
Address: .....  
.....  
Post code: .....  
.....  
Town: .....  
.....  
Telephone number: .....  
.....  
Model: .....  
.....  
Colour: .....  
.....  
Engine no.: .....  
.....

## PRE-DELIVERY INSPECTION

VIN: VGA

The dealer must carry out the pre-delivery inspection and supply the preparation sheet for the delivered vehicle.

### Inspection on delivery

Customer signature

I have inspected the appearance of the vehicle and signed the pre-delivery preparation sheet for my vehicle, I did not notice any anomaly. I have been informed that it is important to read the user manual and maintenance book.

Date:

Customer signature:

Dealer signature

I confirm that the vehicle identified above has undergone preparation and a pre-delivery inspection as specified by PEUGEOT MOTOCYCLES. I have supplied the customer with the user manual and maintenance book. I have explained how to operate the machine's controls and emphasised that it is important to consult the user manual and PEUGEOT MOTOCYCLES warranty conditions.

Date:

Dealer signature:



## INFORMATION

You have just bought a Peugeot vehicle. We would like to thank you for purchasing one of our products.

Your vehicle is built to last but this does not mean that it does not require a minimum amount of maintenance.

Your authorised dealer is familiar with all the vehicle's characteristics and has genuine spare parts and specific tools. He can advise you and service your vehicle in the best conditions according to the established service schedule to ensure that you can enjoy driving it in complete safety.

This manual must be considered as an integral part of the vehicle and must remain with it even if the vehicle is sold on.

It also describes a selection of your vehicle's most common functions.

However, we advise you to read the entire user manual, which is available in digital format at the following address:

<https://www.peugeot-motocycles.fr/documentation>

Scan this QR code for direct access:









In particular, you will find the safety instructions, warnings, important notes and comments in it.

PEUGEOT MOTOCYCLES is constantly improving its vehicles. It therefore reserves the right to remove, modify or add any reference mentioned

The only authentic documents are those available online at the above address.

## The following symbols mean:

	You are advised to read the full version of the user manual.
	Operation that can be dangerous for people.
	Operation that can be hazardous to the vehicle.
	Gives key information concerning operation of the vehicle.
	An asterisk indicates equipment depending on the version.
	The product pollutes. Do not dispose of it in the environment.

## DIAGNOSTIC AND PERSONAL DATA

When diagnostic tools are connected to your vehicle, they collect data. This data includes your vehicle's identification number (VIN).

For further information on your rights or the way PEUGEOT MOTOCYCLES processes data, please refer to our privacy policy at the following address:

<https://peugeot-motocycles.com/fr/mentions-legales/>

Or contact us at:

[dpo@peugeotmotocycles.com](mailto:dpo@peugeotmotocycles.com)

## MANUFACTURER'S WARRANTY

(March 2022 edition)

The manufacturer of your vehicle, PEUGEOT MOTOCYCLES, which has its head office at rue du 17 novembre - 25350 Mandeure (France), hereinafter PEUGEOT MOTOCYCLES, offers you a commercial warranty on your new combustion engine or electric vehicle against any material or construction defects.

These manufacturer warranty terms are also available on the website.

<https://www.peugeot-motocycles.fr/documentation>

### Duration of the warranty

Unless specific contrary provisions have been brought to your attention (warranty extension, fleet agreement, etc.), PEUGEOT MOTOCYCLES grants your vehicle a manufacturer's warranty for a period of:

- 24 months for private use, unlimited mileage;
- 24 months for professional use, limited to 20 000 km (<50cc, cat. L1e & L2e) or 30 000 km (>50cc, cat. L3e & L5e).



The term 'trader' is defined as "any public or private natural or legal person acting for purposes relating to their trading, business, craft, professional or agricultural activity, even when they act in the name or on behalf of another trader".

This warranty starts from the first time the vehicle is registered and applies to your vehicle with the exception of:

- The electric vehicle traction battery for which the current warranty is 24 months or 20 000 km, whichever is reached first, subject to the maintenance charges having been done regularly in accordance with the instructions in the PEUGEOT MOTOCYCLES maintenance manual;
- The electric vehicle traction battery for which the stated nominal capacity has declined by less than or equal to 25%, measured by a PEUGEOT MOTOCYCLES network technician during the warranty period. Due to the inherent chemistry of the battery, a decline in battery capacity (and therefore the vehicle's autonomy) may be observed over time, as the vehicle is used and according to the storage conditions;
- The combustion engine vehicle battery for which this warranty is six months subject to a minimum mileage of 200 km per month;
- The stand and the saddle, for which the warranty period is six months.

### Scope of the manufacturer's warranty

With the exception of the restrictions stated below, this contractual warranty covers the repair or replacement of parts found to be faulty by PEUGEOT MOTOCYCLES or its representative and any ensuing labour costs.

#### It should be noted that:

- The repair or replacement of parts under this manufacturer's warranty does not extend the duration thereof. The warranty covering replacement parts fitted to your vehicle expires on the same date as your vehicle warranty;
- The faulty parts replaced under the warranty will be kept and become the property of PEUGEOT MOTOCYCLES.

## Conditions of application of the commercial warranty

For optimal cover for work to be carried out on your vehicle under this commercial warranty, PEUGEOT MOTOCYCLES recommends that you exclusively entrust said work to a workshop within the authorised network.

If your vehicle is sold on, its successive owners shall benefit from the warranty until its date of expiry on condition that the application conditions of the warranty have been satisfied by each of them. For this purpose, you undertake to transmit the warranty application terms to the buyer of your vehicle, along with evidence of maintenance operations performed.



**The warranty applies on condition that:**

- The first "warranty" service has been carried out and the vehicle has been regularly serviced in line with the instructions of the PEUGEOT MOTOCYCLES maintenance manual, and you can provide proof of this (service monitoring sheet, invoices, etc.). A tolerance of 100 km (or 1 month) in relation to the mileage specified in the maintenance schedule;
- The enhanced maintenance schedule is applied for professional use and, where necessary, for private use;
- Original parts have not been replaced with other components that have not been approved by PEUGEOT MOTOCYCLES and/or the assembly of which does not comply with good practices or the recommendations of PEUGEOT MOTOCYCLES (including, but not limited to, exhaust pipe, cylinder, piston, spark plug and the intake silencer on combustion vehicles, fuses, traction battery modules and the traction battery charger on electric vehicles, etc.);
- The vehicle has not been modified, transformed or equipped with accessories that have not been approved by PEUGEOT MOTOCYCLES (including, but not limited to, additional charger for electric vehicles, alarms, radio, headlights, luggage carriers, boosters, etc.);
- The vehicle has not been used for sports competitions;

**The warranty does not cover:**

- Maintenance operations (such as, but not limited to: oil change, lubrication, adjustment, cleaning, tensioning, etc.) and servicing listed in the PEUGEOT MOTOCYCLES service schedule and required for your vehicle to operate properly;
- The replacement of parts subject to normal wear linked to use of the vehicle, its mileage, its geographical and climatic environment and their non-reusable fastening parts (such as, but not limited to: self-locking nuts, etc.), if this replacement is not due to a manufacturing defect. This includes but is not limited to the following parts:
  - Drive pulley and driven pulley and belt, clutch, rollers, mobile flange, guides, chain, pinion, rear cog;
  - Bearings (wheels, rods, steering, engine, etc.);
  - Bulb, fuse, tyre, brake linings and pads, brake disc, cables and cable controls, spark plug and spark suppressor;
  - Shock absorbers (hydraulic, gas, single spring, elastomer), air filter, entire intake silencer, fuel filter, oil filter, cylinder, piston and piston segments;
  - Exhaust on combustion engine (except unwelded internal elements);
  - Liquids and products (grease, hydraulic fluid, brake fluid, gearbox oil, engine oil and coolant, etc.);
- Repairs resulting from the use of fuels, lubricants or grease other than those recommended by PEUGEOT MOTOCYCLES;
- Repairs resulting from negligence, abnormal use, driving on an impassable or damaged road, failure to follow the advice given in the PEUGEOT MOTOCYCLES service schedule or the user manual, overloading, even temporary, or the driver's lack of experience;

- Repairs due to an accident, theft, fire or natural causes (including, but not limited to hail, flooding, etc.);
- Repairs resulting from lack of vehicle cleanliness;
- Repairs resulting from long storage periods under unsuitable conditions;
- Corrosion or surface oxidation on the chassis, the screws, and, more generally, on all other metal parts, whether treated or not on combustion or electric vehicles (however, pitting corrosion is covered for a period of 24 months);
- The meter or optics for which the presence of steam does not alter information readability or lighting efficiency;
- Noises and vibrations which have no influence on the reliability, safety and road behaviour of the vehicle;
- Any other expenses not specifically included in this warranty or the legal compliance warranty or the legal warranty against hidden defects, such as, but not limited to: costs due to the vehicle being immobilised, loss of use or business, etc.

**Geographical scope of application**

The warranty is applicable in the countries or territories where the vehicle is marketed by the approved PEUGEOT MOTOCYCLES network (in particular, France, Germany, Italy, Spain) a list of which can be consulted on the manufacturer's website:

<http://www.peugeot-motocycles.com>

The vehicle is intended exclusively for sale and use in the above-mentioned countries and territories excluding all other countries or territories, where the applicable standards may be different to those in the above-mentioned countries and territories, such as, but not limited to, the United States of America, etc. Use of the vehicle in these excluded countries or territories is under the user's entire responsibility and excludes the application of this warranty as well as the vehicle manufacturer's responsibility for any reason whatsoever.

In some countries, especially in European Union Member States, the consumer has rights under the applicable national legislation. These rights are not affected by the warranty as defined above.



## IMPORTANT

### Products to use

Fuel Exclusively:  
Unleaded E5 or E10



Engine oil SAE 10W40 / SAE 10W50  
100% synthetic  
Minimum grade API SL

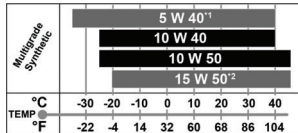

\* Recommended if:

- <sup>1</sup> Minimum annual temperature < -20°C
- <sup>2</sup> Minimum annual temperature > 0°C

Relay box SAE 80W90 API GL4  
oil

Fork oil Hydraulic oil SAE10W

Grease High-temperature grease  
Multi-use grease

Brake fluid Brake fluid DOT4

# MOTUL

### Maintenance advice

Ensure that the servicing schedule for your vehicle is strictly followed to maintain your contractual warranty rights.

A table of inspections for the maintenance schedule is inserted into the maintenance booklet. The registered dealer must add his stamp, the date of servicing and the number of kilometres the vehicle has covered.

In order to maintain maximum safety and reliability of your vehicle, you are advised to have maintenance and repairs carried out by a registered dealer who has the necessary technical training, specific tools and spare parts.

After an accident, it is recommended to have the vehicle inspected and repaired by a registered dealer.

### Cleaning the vehicle



The bodywork is made of plastic parts that can be painted or are shiny. Do not use solvents or cleaning products that are too corrosive.



Do not use high pressure cleaners which may cause water to infiltrate the following parts: seals, bearings and hinges, electrical components such as connectors, contactors and lighting.

Wash the bodywork with soapy water and rinse with generous amounts of clear water.

The vehicle can be dried with a chamois leather.

After washing the vehicle, brake several times at low speed to dry out the brakes.



The vehicle should be washed in a place equipped for wastewater collection.

Certain silicon-based products can alter the quality of the paintwork.

In case of need or doubt, a registered dealer can advise you on using cleaning products or restoring scratched bodywork.

### Environment / Recyclable

Worn parts replaced during routine maintenance (mechanical parts, battery, etc.) must be disposed of with specialised bodies.

At the end of its life, the vehicle must be taken to an authorised centre for recycling.

In all cases, comply with the local laws.



Batteries contain harmful substances. They must be disposed of according to the legal requirements and must under no circumstances be thrown away in the household waste.



## Extended periods of immobilisation and storage

If the vehicle has to be immobilised for more than 1 months, you are advised to carry out the following operations:

GB

### Battery

---



If the vehicle is not used for an extended period, the battery will slowly discharge naturally or due to its electronics or certain accessories and must thus be regularly charged.

---

- Charge the battery to 100% beforehand (The battery's maximum charging current is equal to 1 tenth of its capacity).
  - Use a maintenance charger or charge monthly.
  - Before restarting, the battery must be charged to 100%.
- 



If these recommendations are not followed, the battery may go into deep discharge. In this case the manufacturer's warranty will be void.

---

### Machine

- Empty the fuel tank to avoid fuel build-ups.
- Spray a lubricant onto the metal parts of the vehicle to avoid oxidation.
- Store the vehicle in a dry place.

### Re-starting your vehicle

You are advised to have the vehicle checked over by a registered dealer if it has been immobilized for an extended period.

## QUICK-START GUIDE

### Starting and driving

#### Key-operated ignition switch functions

2 keys are delivered with the vehicle.

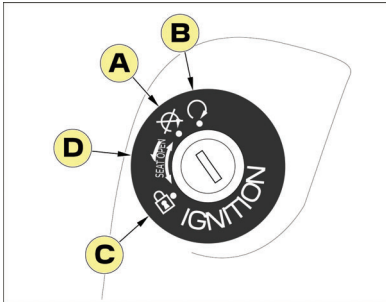

- A. Engine off position
- B. On position
- C. Steering unlocked
- D. Opening the saddle

#### Circuit breaker \*

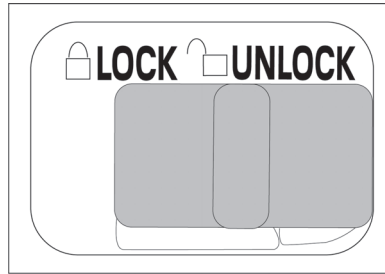

A switch neutralising the ignition circuit is located in the compartment under the saddle. LOCK position. The engine shall not start. UNLOCK position. The engine can be started.

#### Starting the engine

For greater safety, place the vehicle on its central stand before starting the engine.



Ensure that the switch under the saddle is in position UNLOCK\*.

- Turn the ignition key to "ON".
- Ensure that the throttle is in the OFF position.
- Press one of the brake levers while pressing the starter button. Do not press the starter for more than 10 seconds.
- Release the starter button as soon as the engine starts.



If the engine does not start, release the starter button and the brake lever, wait a few seconds and try again.

#### Driving

The vehicle is on its stand with the engine running.

- Squeeze the brake lever with your left hand, grip the grab handle with your right hand and push the vehicle forwards to fold up the central stand.
- Sit on the vehicle.
- Release the left brake and turn the throttle slowly with your right hand to start moving.

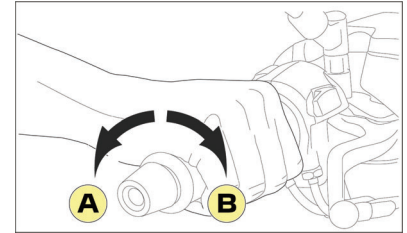

To accelerate, turn the throttle towards (A). To slow down, turn the throttle towards (B).

#### Braking

##### TWEET 50 cc: Conventional braking

The right lever controls the front brake and the left lever controls the rear brake.

##### TWEET 125 cc / TWEET 200 cc: ABS braking system

This is a wheel anti-lock system.

- The ABS system enables the rider to retain control of the vehicle when braking in slippery conditions.
- The right lever controls the front brake and the left lever controls the rear brake.

##### Use of the brakes

- Close the throttle.
- Activate the brake system by gradually increasing the pressure.

#### Stopping the vehicle and parking

The engine is switched off when at idling speed by turning the ignition key to "OFF".

The vehicle should be parked on flat ground.

GB

- Either on the middle stand.
- Or on the lateral stand.

Each time the vehicle is parked, the steering should be locked and the ignition key removed. The ignition circuit can be neutralised by setting the switch under the saddle to "LOCK".

## Controls

### Left controls

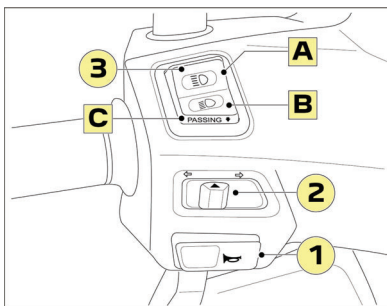

#### 1. Horn switch.

#### 2. Indicator light switch.

To indicate a change of direction, press the switch:

- Either to the right.
- Or to the left.

To stop the indicators flashing, press the switch.

#### 3. Dipped lights/Headlights switch.

The dipped lights/headlights switch has 3 functions:

- A. High beam.
- B. Dip beam.
- C. Flashing the lights.

### Right controls

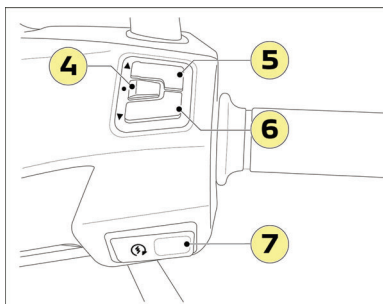

#### 4. Selection/"SELECT" validation button.

This control enables:

- Access to the time setting and units of measurement.
- Confirmation of a choice.

#### 5. "UP" control button . ▲

This control enables:

- Resetting of the trip recorder / the immediate consumption indicators \* (Press and hold for 3 seconds).

#### 6. "DOWN" control button . ▼

This control enables:

- Resetting of the trip recorder / the immediate consumption indicators \* (Press and hold for 3 seconds).

#### 7. Starter switch.



#### [Notice]:

Refer to the online user manual for further information.

## INSTRUMENTS

### Digital display

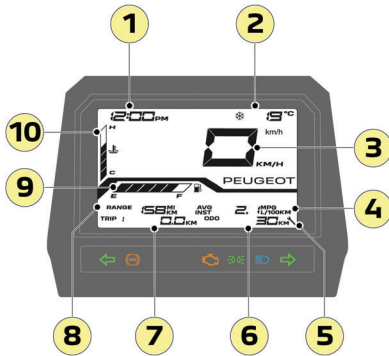

- 1 - Clock
- 2 - Outside temperature gauge (°C or °F).
- 3 - Digital speedometer (km/h or mph).
- 4 - Average consumption indicator / Instantaneous consumption indicator \*.
- 5 - Maintenance indicator.
- 6 - Milometer / Engine oil level control indicator.
- 7 - Tripmeter (TRIP 1 / TRIP 2).
- 8 - Autonomy indicator \*.
- 9 - Fuel gauge.
- 10 - Engine temperature gauge.



#### [Notice]:

Refer to the online user manual for further information.

## Warning lights

The warning lights inform the driver of the start-up of a system or appearance of a malfunction.

- On ignition, some warning lights are displayed for a few seconds.
- Once the engine is started, these warning lights will disappear.

**If they remain on, use the table to check the relevant warning light before driving off.**



In all cases, you are advised to have the vehicle checked by an approved dealer.



The ABS system ON warning light disappears when the vehicle starts to move \*.



Refer to the online user manual for further information.

## EQUIPMENTS



The user manual describes other equipment.

### Adjustment of damper settings \*

Each damper has an adjuster ring that can be used to stiffen or soften the suspension, depending on the vehicle load.

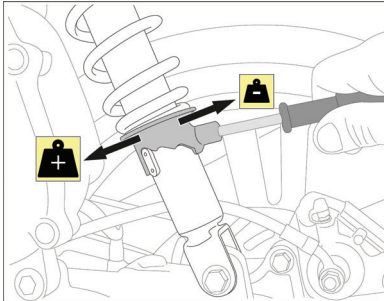

Use the on-board tool to make this adjustment.



To guarantee your comfort and safety, always adjust the damper preload in line with the vehicle load.  
TWEET 125/200 cc: Perform the same setting for the 2 dampers.

### Utility hanger

The utility hanger is located on the rear shield panel. It can be used to attach a maximum load of 2.5 kg.

### Lateral stand \*

**The lateral kickstand is fitted with an ignition cut-out which prevents the engine from being started while the stand is down.**

This system reminds the driver to lift the stand before starting the engine.

If the engine starts with the kickstand down, it is essential to have the circuit checked by an approved dealer.

## ADVICE

### Fuel supply



The engine must be switched off in order to fill the fuel tank in complete safety.

A label affixed near the fuel cap reminds you of the type of fuel to use.

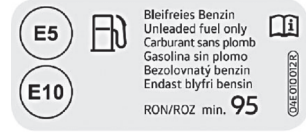

**Any fuel containing up to 10% ethanol can be used (E5, E10).**

**An ethanol content of more than 10% by volume is not permitted. E85 must not be used.**



The fuel tank is located under the saddle.

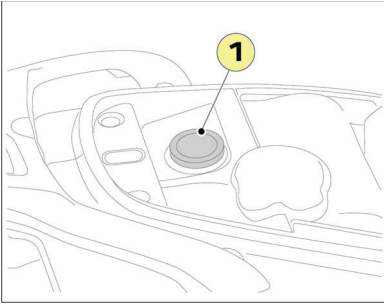

#### 1. Fuel tank cap.

- Insert the petrol pump nozzle into the filling orifice. Make sure the nozzle is correctly inserted into the filling pipe.
- Do not overfill the tank.
- Stop filling when the nozzle stops for the first time.



Do not fill the fuel tank to excess: The fuel may expand due to the engine heat or heat from the sun and overflow.



Any overflows must be wiped up immediately.

#### Checking the engine oil level



Every 1000 km / 600 Mi, the message "Oil ch" appears along with the maintenance indicator on the digital display, indicating that the engine oil level should be checked.

- To correctly measure the oil level, place the vehicle on the centre stand on flat ground.
- Start the engine, let it run for a few minutes and then stop it.
- After switching off the engine, wait for 5 minutes to allow the engine oil time to return to the oil sump.
- Remove the oil filler cap/gauge (1).

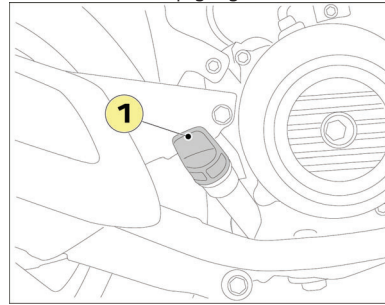

- Wipe the filler cap/gauge using a clean cloth and reinsert it into the filler hole without screwing it up.
- Remove the filler cap/gauge and check the oil level.
- The oil level shall be between the minimum (A) and maximum (B) level marks without exceeding the latter.

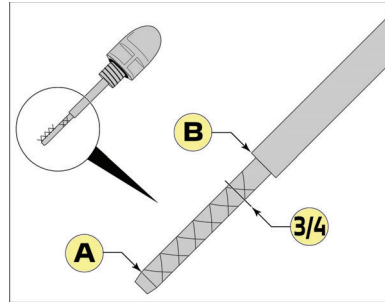

Too much oil will noticeably restrict the vehicle's performance.

- If the oil level is close to the minimum mark or lower, you are advised to immediately top up the level to 3/4 in small amounts using the oil recommended by the manufacturer.



Check the oil level every 1000 km / 600 Mi or before a long journey.

## PERIODIC SERVICING

### Special important points:

- Compliance with the servicing schedule in light of the conditions of use will help keep your vehicle running smoothly over time and preserve its qualities, while being covered by the warranty. We recommend that you entrust these operations to an authorised Peugeot Motorcycles dealer who has been trained by the manufacturer and has suitable tools.
- There is no need for an annual test if a periodic test has been conducted during the year.
- From 25000 km (15600 mi), servicing must be performed by repeating operations from 5000 km (3100 mi).
- Clean or replace the air filter (engine/transmission) more often if the vehicle is used in particularly dusty or humid areas.

### Heavy duty servicing / Harsh conditions of use (\*):

Components marked with an asterisk must be maintained more regularly if the vehicle is used in either of the following conditions:

Humid, dusty, high heat area, predominantly urban use, at temperatures frequently dropping below -5°C, Repeated short or door-to-door trips with a cold engine at a low temperature, etc.

Vehicles used for commercial purposes (home deliveries, couriers, etc.) should, in particular, be subject to heavy duty servicing (The service mileage should be halved).

### Care / Cleanliness:

In light of the design and aesthetic appeal of a two-wheeled vehicle, numerous components are exposed to the elements. This vulnerability may result in functional or cosmetic damage (corrosion, etc.), even on high-quality parts. This is why proper regular servicing helps not only preserve its appearance, smooth running and your enjoyment; it is also essential to maintain your Warranty rights.

## SERVICE SCHEDULE TWEET 50 CC

Servicing must be performed by a PEUGEOT MOTOCYCLES registered representative.

Operations to be carried out	300 km 180 mi Or 1 months	5000 km 3100 mi	10000 km 6200 mi	15000 km 9300 mi	20000 km 12400 mi	Annual maintenance
<b>Engine</b>						
Engine oil	R Every 5000 km (2500 km if harsh use servicing)					R
Oil filter (Screen)	C	C	C	C	C	C
Valve clearances	I	I	I	I	I	
Spark plug			R		R	
Intake air filter	R Every 10000 km (5000 km if harsh use servicing)					
Intake silencer drain		C	C	C	C	C
Drive pulley / Flange wear		I	I	I	R	
Drive pulley rollers and guides		I	I	I	R	
Transmission belt			R		R	
Driven pulley caged needle bearing		L	L	L	L	
Clutch lining wear			I		R	
Driven pulley			I		R	
Transmission fluid	R	R	R	R	R	
Petrol pipe: No leaks or cracks	I	I	I	I	I	I
Canister unit, canister valves and hoses			I		I	
<b>I: Inspect, clean, adjust, replace if necessary.</b> <b>R: Change.</b>						
<b>C: Clean, replace if necessary.</b> <b>L: Lubricate, oil</b>						

GB

**GB**

Operations to be carried out	300 km 180 mi Or 1 months	5000 km 3100 mi	10000 km 6200 mi	15000 km 9300 mi	20000 km 12400 mi	Annual maintenance
<b>Cycle part</b>						
Steering: No sticking point / No play	I	I	I	I	I	
Wheels: Condition and runout / No play	I	I	I	I	I	
Tyres: No cracks, wear and pressure	I	I	I	I	I	I
Fork / Front suspension: Condition, operation and no leakage	I	I	I	I	I	
Fork oil					R	
Rear suspension: Condition, operation and no leakage	I	I	I	I	R	
Throttle control: Operation, play and lubrication	I	I + L	I + L	I + L	I + L	
Moving parts and cables		L	L	L	L	
Kickstands: Operation and lubrication		I + L	I + L	I + L	I + L	
Tightness of nuts and bolts	I	I	I	I	I	
<b>Braking system</b>						
Brake fluid level / No leakage	I	I	I	I	I	I
Brake fluid	R Once every 2 years					
Brake calipers: Cleanliness, guide pins, Functioning			I + L		I + L	
Brake pad wear		I	I	I	I	
Brake disk wear		I	I	I	I	
Brake hoses: No leaks or cracks		I	I	I	I	
Cable-operated brake control: Condition and lubrication		I + L	I + L	I + L	I + L	
Brake lining wear		I	I	I	I	
Brake levers		L	L	L	L	
<b>I: Inspect, clean, adjust, replace if necessary. R: Change.</b>			<b>C: Clean, replace if necessary. L: Lubricate, oil</b>			

Operations to be carried out	300 km 180 mi Or 1 months	5000 km 3100 mi	10000 km 6200 mi	15000 km 9300 mi	20000 km 12400 mi	Annual maintenance
<b>Electrical equipment</b>						
Lighting and signalling	I	I	I	I	I	I
Headlight height adjustment	I	I	I	I	I	
Brake light switches	I	I	I	I	I	I
Battery: Charge level and no leakage	I	I	I	I	I	I
<b>Miscellaneous</b>						
Processors: Reading of fault codes and update	I	I	I	I	I	I
Overall operation: Road test	I	I	I	I	I	I
<p style="text-align: center;"><b>I: Inspect, clean, adjust, replace if necessary.</b>      <b>C: Clean, replace if necessary.</b>  <b>R: Change.</b>      <b>L: Lubricate, oil</b></p>						
<b>Servicing time in tenths of an hour (0.5 h = 30 mn)</b>						
Reception and Treatment	0.1	0.1	0.1	0.1	0.1	0.1
TWEET 50 cc	1.5	2.0	2.5	2.0	3.2	0.5
<b>Maintenance times are indicative. They do not take into account the replacement of wear parts.</b>						

## SERVICE SCHEDULE TWEET 125 / 200 CC

Servicing must be performed by a PEUGEOT MOTOCYCLES registered representative.

Operations to be carried out	500 km 300 mi Or 1 months	5000 km 3100 mi	10000 km 6200 mi	15000 km 9300 mi	20000 km 12400 mi	Annual maintenance
<b>Engine</b>						
Engine oil <sup>1</sup>	R	R Every 5000 km (Asia: R Every 2500 km)				R
Oil filter (Screen)	C		C		C	C
Valve clearances		I	I	I	I	
Spark plug			R		R	
Intake air filter		R Every 10000 km (5000 km if harsh use servicing)				
Intake silencer drain		C	C	C	C	C
Drive pulley / Flange wear		I	I	I	R	
Drive pulley rollers and guides		I	I	I	R	
Transmission belt			R		R	
Driven pulley caged needle bearing		L	L	L		
Clutch lining wear			I		R	
Driven pulley			I		R	
Transmission fluid	R	R	R	R	R	
Petrol pipe: No leaks or cracks	I	I	I	I	I	I
Canister unit, canister valves and hoses			I		I	
<b>I: Inspect, clean, adjust, replace if necessary. R: Change.</b>			<b>C: Clean, replace if necessary. L: Lubricate, oil</b>			

<sup>1</sup> TWEET 125 cc PRO: R to 0 km







Operations to be carried out	500 km 300 mi Or 1 months	5000 km 3100 mi	10000 km 6200 mi	15000 km 9300 mi	20000 km 12400 mi	Annual maintenance
<b>Cycle part</b>						
Steering: No sticking point / No play	I	I	I	I	I	
Wheels: Condition and runout / No play	I	I	I	I	I	
Tyres: No cracks, wear and pressure	I	I	I	I	I	I
Fork / Front suspension: Condition, operation and no leakage	I	I	I	I	I	
Fork oil					R	
Rear suspension: Condition, operation and no leakage	I	I	I	I	R	
Throttle control: Operation, play and lubrication	I	I + L	I + L	I + L	I + L	
Moving parts and cables		L	L	L	L	
Kickstands: Operation and lubrication		I + L	I + L	I + L	I + L	
Tightness of nuts and bolts	I	I	I	I	I	
<b>Braking system</b>						
Brake fluid level / No leakage	I	I	I	I	I	I
Brake fluid	R Once every 2 years					
Brake calipers: Cleanliness, guide pins, Functioning			I + L		I + L	
Brake pad wear		I	I	I	I	
Brake disk wear		I	I	I	I	
Brake hoses: No leaks or cracks		I	I	I	I	
Brake levers		L	L	L	L	
<b>I: Inspect, clean, adjust, replace if necessary.</b> <b>R: Change.</b> <b>C: Clean, replace if necessary.</b> <b>L: Lubricate, oil</b>						

**GB**

Operations to be carried out	500 km 300 mi Or 1 months	5000 km 3100 mi	10000 km 6200 mi	15000 km 9300 mi	20000 km 12400 mi	Annual maintenance
<b>Electrical equipment</b>						
Lighting and signalling	I	I	I	I	I	I
Headlight height adjustment	I	I	I	I	I	
Brake light switches	I	I	I	I	I	I
Battery: Charge level and no leakage	I	I	I	I	I	I
<b>Miscellaneous</b>						
Processors: Reading of fault codes and update	I	I	I	I	I	I
Overall operation: Road test	I	I	I	I	I	
			<b>I: Inspect, clean, adjust, replace if necessary. R: Change.</b>		<b>C: Clean, replace if necessary. L: Lubricate, oil</b>	
<b>Servicing time in tenths of an hour (0.5 h = 30 mn)</b>						
Reception and Treatment	0.1	0.1	0.1	0.1	0.1	0.1
TWEET 125 / 200 cc	1.0	1.8	2.4	1.8	3.2	0.5
<b>Maintenance times are indicative. They do not take into account the replacement of wear parts.</b>						

\_\_\_\_\_ km  
\_\_\_\_\_ *mi*  
 \_\_\_\_\_ / \_\_\_\_\_ / \_\_\_\_\_

\_\_\_\_\_ km  
\_\_\_\_\_ *mi*  
 \_\_\_\_\_ / \_\_\_\_\_ / \_\_\_\_\_

\_\_\_\_\_ km  
\_\_\_\_\_ *mi*  
 \_\_\_\_\_ / \_\_\_\_\_ / \_\_\_\_\_

\_\_\_\_\_ km  
\_\_\_\_\_ *mi*  
 \_\_\_\_\_ / \_\_\_\_\_ / \_\_\_\_\_

\_\_\_\_\_ km  
\_\_\_\_\_ *mi*  
 \_\_\_\_\_ / \_\_\_\_\_ / \_\_\_\_\_

\_\_\_\_\_ km  
\_\_\_\_\_ *mi*  
 \_\_\_\_\_ / \_\_\_\_\_ / \_\_\_\_\_

\_\_\_\_\_ km  
\_\_\_\_\_ *mi*  
 \_\_\_\_\_ / \_\_\_\_\_ / \_\_\_\_\_

\_\_\_\_\_ km  
\_\_\_\_\_ *mi*  
 \_\_\_\_\_ / \_\_\_\_\_ / \_\_\_\_\_

\_\_\_\_\_ km  
\_\_\_\_\_ *mi*  
 \_\_\_\_\_ / \_\_\_\_\_ / \_\_\_\_\_

FR

GB

DE

IT

ES

NL

GR

SE

PT

FI

DK

\_\_\_\_\_ km

\_\_\_\_\_ *mi*



----- / ----- /-----

\_\_\_\_\_ km

\_\_\_\_\_ *mi*



----- / ----- /-----

\_\_\_\_\_ km

\_\_\_\_\_ *mi*



----- / ----- /-----

\_\_\_\_\_ km

\_\_\_\_\_ *mi*



----- / ----- /-----

\_\_\_\_\_ km

\_\_\_\_\_ *mi*



----- / ----- /-----

\_\_\_\_\_ km

\_\_\_\_\_ *mi*



----- / ----- /-----

\_\_\_\_\_ km

\_\_\_\_\_ *mi*



----- / ----- /-----

\_\_\_\_\_ km

\_\_\_\_\_ *mi*











----- / ----- /-----

\_\_\_\_\_ km

\_\_\_\_\_ *mi*



----- / ----- /-----

<p>----- km</p> <p>----- mi</p>	
<p>----- km</p> <p>----- mi</p>	
<p>----- km</p> <p>----- mi</p>	
<p>----- km</p> <p>----- mi</p>	
<p>----- km</p> <p>----- mi</p>	
<p>----- km</p> <p>----- mi</p>	
<p>----- km</p> <p>----- mi</p>	
<p>----- km</p> <p>----- mi</p>	
<p>----- km</p> <p>----- mi</p>	

- FR
- GB
- DE
- IT
- ES
- NL
- GR
- SE
- PT
- FI
- DK

FR

----- km



GB

----- mi

DE

----- km



----- mi

IT

----- km



----- mi

ES

----- km



----- mi

NL

----- km



----- mi

GR

----- km



----- mi

SE

----- km



----- mi

PT

----- km



----- mi

FI

----- km



----- mi

DK





Peugeot Motorcycles recommends



Quality management system certified ISO  
9001 by UTAC



**Peugeot Motorcycles SA**  
**Rue du 17 Novembre**  
**F-25350 Mandeure**

Tél. +33(0)3 81 36 80 00

RCS Belfort B 875 550 667

[www.peugeot-motocycles.fr](http://www.peugeot-motocycles.fr)  
[www.peugeot-motocycles.com](http://www.peugeot-motocycles.com)

**0 800 007 216**

Service & appel  
gratuits

Dans un souci constant d'amélioration Peugeot Motorcycles se réserve le droit de supprimer, modifier ou ajouter toutes références citées.  
DQ/APV du 02/2024 (photos non contractuelles).







# PEUGEOT MOTOCYCLES



Guide d'utilisation en ligne  
Online user's guide