



PEUGEOT
MOTOCYCLES

PULSION EVO

NOTICE D'UTILISATION

OWNER'S MANUAL

Welcome



TABLE OF CONTENTS

Information..... 1
 Safety advice..... 1
 Characteristics..... 2
 Vehicle identification.....6
 Products to use..... 6
 Information about the instructions..... 6
 Description of the vehicle.....8
 Controls..... 9
 Left controls.....9
 Right controls.....9
 Instruments.....10
 Digital display.....10
 Setting the digital display..... 12
 Indicator lights and warning lights..... 12
 Pairing a phone with Bluetooth..... 12
 Description of the indicators..... 13
 Key-operated ignition switch functions 14
 Equipments.....14
 Adjustable windshield (Pulsion Evo Urban).....14
 Adjusting the handlebar..... 14
 Storage compartment / Accessory
 socket (USB / USBC)..... 15
 Utility hanger.....15
 Storage compartment.....15
 Rear luggage carrier (Depending on
 model / Optional)..... 16
 Top case (Pulsion Evo Urban)..... 16
 Lateral stand.....16
 Adjustment of damper settings..... 17
 Checks to perform before use..... 17
 Advice for starting up and driving.....17
 Warning..... 17
 Eco mode.....17
 Driving on flooded roads..... 18
 Inspection before setting off.....18

Starting the engine..... 18
 Driving..... 18
 Braking system..... 19
 Switching off the engine and parking..... 19
 Fuel supply.....19
 Running in the engine.....20
 Service operations.....21
 Maintenance advice.....21
 Environment / Recycling..... 21
 Cleaning the vehicle..... 21
 Spark plug inspection or replacement.....21
 Checking the engine oil level..... 22
 Changing the engine oil.....23
 Draining the relay box.....23
 Coolant.....23
 Replacing the air filter.....24
 Throttle cable play..... 24
 Tyres.....25
 Brake inspection.....25
 Battery.....26
 Headlight adjustment..... 27
 Fuses.....28

GB

INFORMATION

You have just bought a Peugeot vehicle.

We would like to thank you for purchasing one of our products.

Please take some time to read this manual carefully before using the vehicle.

This user manual should always be kept in the boot of the vehicle. It contains instructions for use, checks and maintenance of the vehicle, and important safety instructions intended to protect the user and third parties against accidents.

It will give you plenty of advice on how to keep your vehicle in full working order.

Your vehicle is built to last but this does not mean that it does not require a minimum amount of maintenance.

Your authorised dealer is familiar with all the vehicle's characteristics and has genuine spare parts and specific tools. He can advise you and service your vehicle in the best conditions according to the established service schedule to ensure that you can enjoy driving it in complete safety.

This manual must be considered as an integral part of the vehicle and must remain with it even if the vehicle is sold on.

In our permanent concern to make improvements PEUGEOT MOTOCYCLES reserves the right to suppress, modify, or add any reference mentioned. Reproductions or translations, even partial, of this document, are not permitted without the written authorization of PEUGEOT MOTOCYCLES.

SAFETY ADVICE

A inexperienced motorcyclist should make himself completely familiar with his vehicle before going out in traffic. You are strongly advised not to lend your vehicle to an inexperienced rider.

To ride a motorbike, you are required by law to hold a licence or to have completed specific training with a professional, depending on the applicable legislation and based on its category.

Wearing an approved helmet and gloves is obligatory for the user and passenger. You are also advised to wear goggles and light-coloured or reflective clothing adapted to motorcycling.

In some countries, the applicable legislation may not authorise transportation of a passenger, and elsewhere it may oblige motorcycle users to contract a civil liability insurance policy to protect third parties and the passenger against potential damage resulting from an accident.

Driving whilst under the influence of alcohol, drugs or certain medicines is inexcusable and dangerous for yourself and others.

Excessive speed is an important factor in many accidents. You must observe the road signs and signals and adapt your speed to the weather conditions.

The engine and the exhaust system components can reach very high temperatures. When parking your vehicle, be careful to avoid contact with inflammable materials which could cause a fire or with parts of the body which could result in serious burns.

Luggage carriers and panniers approved by PEUGEOT MOTOCYCLES are available as options (depending on the model). The assembly instructions must be complied with and the maximum permissible load (3 to 5 kg depending on the equipment) must not be exceeded.

Fitting accessories such as the driver's apron, top-case, etc. may affect the vehicle's stability (wind factor, load, etc.).

When riding the vehicle fitted with accessories, the driver should reduce speed.

Parking in the sun: The reflection of the sun's rays on the windshield can, at certain times of the day, create a high temperature on the dashboard. This can lead to warping. To prevent this, do not park the vehicle in the sun.

Mounting adaptable parts that have not been approved by PEUGEOT MOTOCYCLES, which alter the technical characteristics or performances of the vehicle is forbidden. Any modification will invalidate the warranty and the vehicle will no longer be in compliance with the version approved by the appropriate services.

The presence of mist on the inside of the headlight glass is normal. It disappears a few minutes after the lights are switched on.

GB

CHARACTERISTICS

		PULSION EVO
Official type-approval code		Z3A
Weight in kg		
Unladen weight		147 (Version GT) 154 (Version Urban)
In working order		158 (Version GT) 165 (Version Urban)
Authorised maximum. Total weight of the vehicle, the user, the passenger, the accessories and luggage.		365

Dimensions in mm

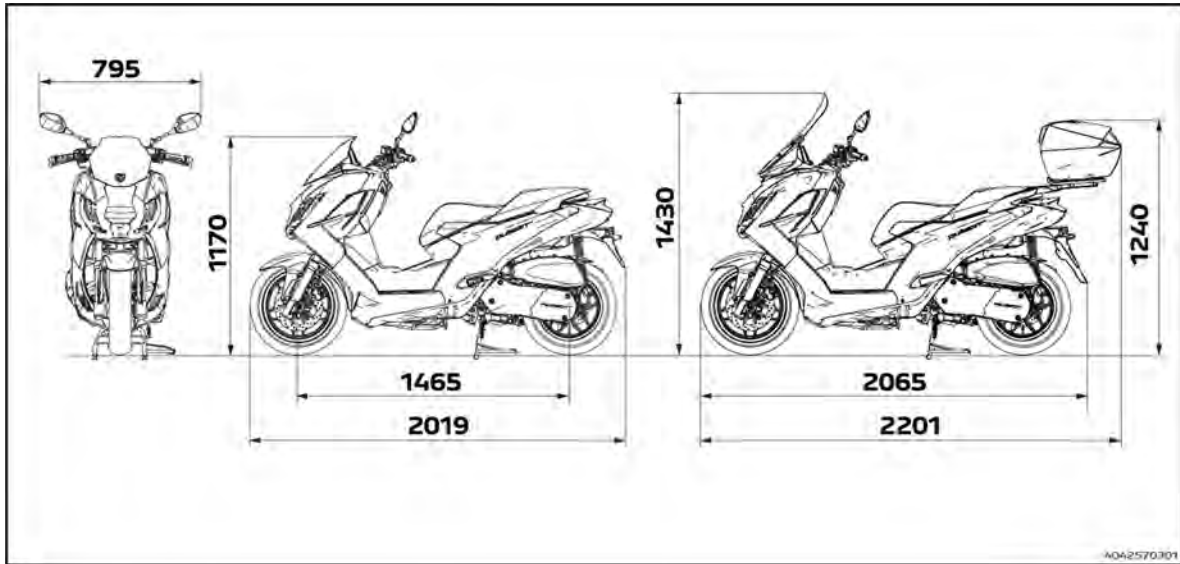

	PULSION EVO
Official type-approval code	Z3A
Engine	
Identification	P1P52MI-5
Engine type	4-stroke single-cylinder
Cubic capacity	125 cc
Bore x stroke in mm	52.4 x 57.8 mm
Maximum power	9.9 kW at 8800 rpm
Maximum torque	12 Nm at 6800 rpm
Cooling	Fluid cooling system
Fuel supply	Indirect electronic injection
Spark plug	NGK CPR9EB-9
Lubrication	Pressurised wet sump lubrication
Exhaust	Catalytic
Anti-pollution standard	Euro 5+
Consumption ^a	2.5 l/100
CO ² emission (On cycle)	54 g/km

^a These consumption values are established according to Regulation 134/2014 Appendix VII. They may vary according to driving behaviour, traffic conditions, weather conditions, the load in the vehicle, vehicle maintenance and use of the accessories etc.

		PULSION EVO
Official type-approval code		Z3A
Capacities in litres		
Engine oil		1
Relay box oil		0.18
Coolant		0.7
Fuel tank		11.1
Fork oil		0.127 cc per tube
Tyre dimensions		
Front		120/70 - 14
Minimum load index and speed rating		42K
Rear		130/70 - 13
Minimum load index and speed rating		60K
Pressure in bars		
Front	Solo	2.2
	Pillion	2.2
Rear	Solo	2.4
	Pillion	2.6

	PULSION EVO
Official type-approval code	Z3A
Suspension	
Front	Hydraulic telescopic fork Ø33 mm Travel: 95 mm
Rear	2 adjustable combined spring hydraulic shock absorbers Travel: 90 mm
Brakes	
Front	1 Ø260 mm disks
Rear	1 Ø210 mm disks
Electrical equipment	
Headlights	LED
"Side light" bulbs	LED
Indicator bulbs	LED
Rear light	LED
Number plate light	LED
Battery	12V - 8.6Ah SLA BTZ10S battery

GB

VEHICLE IDENTIFICATION

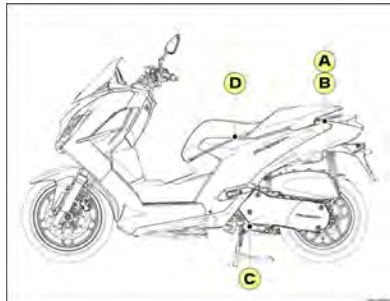

- A.** Manufacturer's plate.
B. Vehicle identification number (V.I.N.).
 The manufacturer's plate and identification number are visible after lifting a flap at the rear of the under-seat storage compartment.
C. Engine number.
D. Tyre pressure label.
 The label affixed under the saddle gives the cold tyre pressures when riding alone and with a passenger.

✓ Temperature variations modify tyre pressure.
 The tyre pressure must be checked once a month when cold.

Products to use

Fuel	Unleaded
4 stroke engine oil	SAE 5W50 100% synthetic Minimum grade API SN
Relay box oil	SAE 80W90 API GL4
Fork oil	Hydraulic oil SAE10W
Grease	High-temperature grease Multi-use grease
Brake fluid	DOT 5.1
Coolant	MOTOCOOL FACTORY LINE -35°C & MOTOCOOL EXPERT -37°C Anti-corrosion and anti-freeze Protection -37°C/-35°F Nitrite free / Amine free / Silicate free

MOTUL

INFORMATION ABOUT THE INSTRUCTIONS

Specific information is indicated by the following symbols:



Möbius band
 Recyclable.
 Means that the product or the package can be recycled.



Explosive
 The product may explode upon contact with a naked flame, spark or static electricity, or due to the effect of heat, an impact or friction.
 Handle and keep away from heat sources and other causes of sparks.



Flammable
 The product may ignite in contact with a naked flame, a spark or static electricity, or due to the effect of heat, friction, in contact with the air or in contact with water, releasing inflammable gases.
 Handle and keep away from heat sources and other causes of sparks.



Corrosive
 The product is corrosive.
 It can attack (corrode) or destroy metals.
 Contact with the product or splashes of the product may burn the skin and cause lesions to the eyes. Avoid any contact with the eyes and skin. Do not inhale.



Harmful to health

The product can be poisonous in high doses.

It may irritate the skin, eyes and airways.

It may cause skin allergies.

It may cause drowsiness or dizziness. Avoid all contact with the product.



Toxic or fatal

The product can rapidly be fatal.

It poisons rapidly, even at low doses. Wear protective equipment.

Avoid any contact (oral, skin, inhalation) with the product and wash all exposed areas carefully after use.



Harmful for the environment

The product pollutes.

It has a harmful effect (in the short and/or long term) on organisms in aquatic environments.

Do not dispose of it in the environment.



Do not throw away into a garbage can

One of the product's component is toxic and can be hazardous to environment. Do not throw the used product in the dustbin. Take it back to the trader or to a specific waste disposal site.



People's safety

Operation that can be dangerous for people.

People's safety can be seriously affected if the recommendations are not fully respected.



Important

Operation that can be hazardous to the vehicle.

Indicate the specific procedures that shall be followed in order not to damage the vehicle.



Note

Gives key information concerning operation of the vehicle.

DESCRIPTION OF THE VEHICLE

1. Instrument panel
2. Adjustable windshield¹
3. Brake fluid level
4. Left brake lever (Rear brake)
5. Utility hanger
6. Storage compartment / Accessory socket
7. Lockable fuel tank flap
8. Top case¹
9. Adjustable shock absorbers
10. Folding passenger footrests
11. Central stand
12. Lateral stand
13. Ignition switch
14. Expansion tank / Coolant level
15. Battery / Fuses
16. Right brake lever (Front brake)
17. Engine oil gauge
18. Grab handle
19. Storage compartment



¹ Pulsion Evo Urban

CONTROLS

Left controls

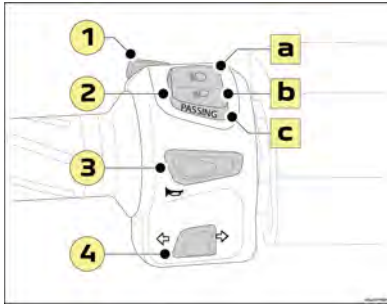

1. "EXIT" control

This control enables:

- The trip meter/average consumption indicator to be reset (See chapter: [Instruments](#) page 10).

2. Dipped lights/Headlights switch

The dipped lights/headlights switch has 3 functions:

- A. High beam
- B. Dip beam
- C. Flashing the lights

3. Horn switch

4. Indicators switch

To indicate a change of direction, press the switch:

- Either to the right.
- Or to the left.

To stop the indicators flashing, press the switch.

Right controls

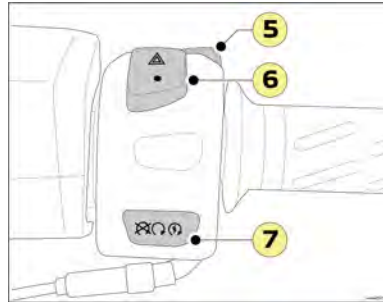

5. "OK" control

This control enables:

- The trip meter/average consumption indicator to be reset (See chapter: [Instruments](#) page 10).

6. Hazard warning light switch

The hazard warning lights only work with the ignition key in the "ON" position.

The hazard warning lights are switched off automatically 1 hour after the ignition was switched off, to preserve the battery.

7. Emergency stop button / Starter switch

- ☒ Set the button to this position in case of emergency to stop the engine.
- ☞ Set the button to this position before starting the engine.
- ⚙️ Press this button and simultaneously press the right or left brake lever to start the engine.

INSTRUMENTS

Digital display



1. Clock.

Set the clock (See chapter: [Setting the digital display](#) page 12).

2. Call notification

Pictogram indicating an incoming call when a Smartphone is connected via Bluetooth.

3. Message notification

Pictogram indicating a message when a Smartphone is connected via Bluetooth (flashes for 1 minute).

4. Bluetooth connection

Pictogram indicating connection with a Smartphone via Bluetooth.

5. Outside temperature gauge (°C or °F).

The temperature shown is that read on the front of the vehicle.



The "risk of black ice" symbol comes on as soon as the temperature falls below 3°C.

6. Digital speedometer (km/h or mph).

The digital speed indicator displays the vehicle's driving speed.

7. Average consumption indicator (AVG) / Instantaneous consumption indicator (INST).

- The average consumption indicator indicates the fuel consumption from the last daily counter reset.
- The instantaneous consumption indicator displays the amount of fuel consumed in the last few seconds.

Press briefly on the OK or EXIT button to switch between the average consumption indicator and the instantaneous consumption indicator.

Reset the average consumption indicator:

This operation can only be carried out when the vehicle is stopped.

- Press and hold the OK or EXIT button for more than 3 seconds to reset the average consumption indicator to zero.

The day counter displayed is also reset to zero.

8. Maintenance indicator.

- Each time the ignition is switched on, the display indicates the mileage remaining before the next service.
- When the kilometres to maintenance reach zero, the maintenance symbol remains lit on the display.

Maintenance frequency (Default value)

5000 km



This period does not include the first inspection at 500 km and concerns normal servicing.
See service book for harsh-use servicing.

• Resetting the maintenance counter.

- With the ignition off, press and hold the OK button then switch on the ignition. The maintenance counter flashes.
- Release the OK button.
- Press and hold down the "OK" button for more than 3 seconds to switch off the maintenance symbol and reset the maintenance counter.
- Turn off the ignition.



You are advised to go to an authorised dealer to have the vehicle serviced and the message on the maintenance indicator erased.

• Choice of maintenance interval (Consult the maintenance manual).

- With the ignition off, press and hold the OK button then switch on the ignition. The maintenance counter flashes.
- Release the OK button.
- Select the maintenance interval by pressing briefly on the OK or EXIT buttons.

- Press and hold the OK button for more than 3 seconds to confirm the setting.
- Turn off the ignition.

Available maintenance intervals
2500 km
3000 km
5000 km (Default value)
10000 km

9. Milometer.

- The tripmeter displays and stores the number of kilometres travelled by the vehicle. The machine total kilometres remains in the memory when the battery is disconnected.

10. Tripmeter.

- The tripmeter displays and stores the number of kilometers travelled during a given period.

Resetting the tripmeter:

This operation can only be carried out when the vehicle is stopped.

- Press and hold down the OK and EXIT buttons for more than 3 seconds to reset the tripmeter.

The average consumption counter is also reset to zero .

11. Autonomy indicator.

- The autonomy indicator displays the number of kilometers that can be traveled with the fuel remaining in the tank (based on the average consumption over the last 10 minutes).

✓ This figure may vary following a change in driving or in the relief, resulting in a significant variation in instantaneous consumption.

12. Fuel gauge.

When the fuel tank is full all the segments of the fuel gauge are lit.



The final segment (r) is the reserve indicator. When the reserve level is reached, the last segment flashes, as well as the fuel pump icon. This indicates that there is approximately 1 liter of fuel remaining.

✓ Fill the tank as soon as possible to prevent a breakdown.

13. Engine temperature gauge.

The high temperature alert is indicated when all segments are flashing, along with the "temperature" symbol (t).



It is advisable to stop the engine and let it cool down. If the fault continues, have the vehicle checked by an approved dealership.



The presence of mist on the inside of the instrument panel is normal. It disappears a few minutes after the lights are switched on.

14. Area displaying the warning lights / Operating lights.

(See chapter: [Description of the indicators](#) page 13)

Setting the digital display

Distance and temperature units of measurement.

- Turn on the ignition.
- Press and hold down the "EXIT" button for more than 3 seconds. The units symbol flashes.
- Modify the units by briefly pressing the OK button.
- Press and hold down the "OK" button for more than 3 seconds to confirm this choice.
- Turn off the ignition.

Clock format and settings adjustment.

- Turn on the ignition.
- Press the "OK" button for more than 3 seconds to enter the clock format settings.
- Select the format by pressing briefly on the OK or EXIT buttons (12h > AM or PM > 24h).
- Press and hold the OK button for more than 3 seconds to confirm this selection and move on to setting the clock format.
- The hour digits flash: press the OK or EXIT buttons briefly to change the setting.
- Press and hold the OK button for more than 3 seconds to confirm this selection and move on to setting the minutes.
- The minute digits flash: press the OK or EXIT buttons briefly to change the setting.
- Press and hold the OK button for more than 3 seconds to confirm the settings.
- Turn off the ignition.



Press and hold down the "EXIT" button for more than 3 seconds to exit the adjustment procedure.

Indicator lights and warning lights

The warning lights inform the driver of the start-up of a system or appearance of a malfunction.

- On ignition, some warning lights are displayed for a few seconds.
- Once the engine is started, these warning lights will disappear.

If they remain on, use the table to check the relevant warning light before driving off. (See chapter: [Description of the indicators](#) page 13)

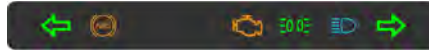

The ABS system ON warning light disappears when the vehicle starts to move.

- Emissions control system failure warning light. Engine self-diagnostic (MIL).
- Anti-lock Braking System indicator (ABS).

These indicators light up in two ways (steady or flashing).



In all cases, you are advised to have the vehicle checked by an approved dealer.



For further information concerning the indicator lights, please consult the table in the relevant section.

Pairing a phone with Bluetooth



For safety reasons and because the driver's full attention is required, using a smartphone while driving is prohibited.



Enable your smartphone's mobile browser data (or Wi-Fi).
If another smartphone is already connected to the vehicle, pairing with a second smartphone will be rejected. Check that there are no other connected smartphones nearby.

1. Activate the Bluetooth function on your smartphone.
2. Select the name of the system from the list of devices detected (Bluetooth menu).
3. On the system, accept the smartphone connection request.











If this fails, you are advised to deactivate then reactivate the Bluetooth function on your phone.



Telephones (models, operating system versions) each have their own specific features which may affect the pairing process.
Some telephones may not be compatible.

Description of the indicators

Indicator	Status	Cause	Actions / Observations
 Left indicators	Flashing	The indicator control is activated to the left.	If the warning light flashes quickly, there is a fault in the direction indicators.
 Wheel anti-lock system (ABS)	Flashing / fixed	The ABS system is faulty.	<p>The vehicle has a standard braking system. Drive carefully at moderate speed and have the vehicle checked by an authorised dealer.</p> <hr/> <p> At very slow speeds and during shut-down, the lamp ABS blinks slowly, indicating that the system is deactivated.</p>
 Malfunction warning light for the antipollution system / Engine self-diagnostic	Fixed	The anti-pollution system is faulty.	The engine power may be limited. You are advised to have the vehicle checked by an authorised dealer.
	Flashing	The engine control system is faulty.	You are advised to have the vehicle checked by an authorised dealer.
 "Side light" bulbs	Fixed	The parking lights are on.	
 High beam	Fixed	The lighting control is in the "main-beam headlamps" position.	
 Right indicators	Flashing	The indicator control is activated to the right.	If the warning light flashes quickly, there is a fault in the direction indicators.
 Hazard warning lights	Flashing	The hazard warning lights control is activated.	The left and right direction indicators, as well as their associated warning lights, flash simultaneously. Automatic cut out after 1 hour to preserve the battery.

GB

KEY-OPERATED IGNITION SWITCH FUNCTIONS

2 keys are delivered with the vehicle.

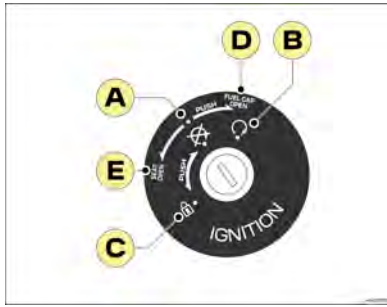

A. Engine off position

The engine is off. Power to the electrical circuit is off. The key can be removed.

B. On position

Power to the electrical circuit is on. The engine can be started. The key cannot be removed.

C. Steering unlocked

From the engine off position, the handlebars must be turned to the left, and the key must be simultaneously inserted and turned to the left. The key can be removed.

D. Opening the fuel flap

From the engine-off position, the key must be simultaneously pushed in and turned to the right to open the fuel flap.

E. Opening the storage compartment

From the engine stop position, the key must be turned to the left to unlock the saddle.

EQUIPMENTS

Adjustable windshield (Pulsion Evo Urban)

The windshield can be adjusted to 2 heights according to the driver's preference.

- A. High position.
- B. Low position.

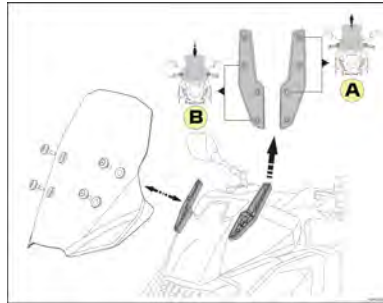

- Remove the 4 bolts.
- Remove the windshield from its bracket and position it to the required height.
- Affix it and tighten the screws (Tightening torque: 10 Nm).



Take care not to scratch the windshield when handling it.

Tighten the screws to the recommended torque to prevent the windshield from detaching when the vehicle is in motion.

Adjusting the handlebar

- Slightly loosen the handlebar screws.
- Tilt the handlebar forwards or backwards according to your preference.

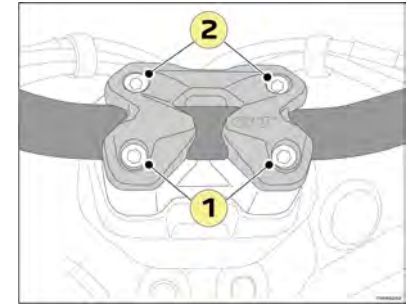

- First tighten the rear screws (1), followed by the front screws (2) (Tightening torque: 25 Nm).

- C. Centring marks on the handlebar.
- D. Marks for standard position / Adjustment limit.

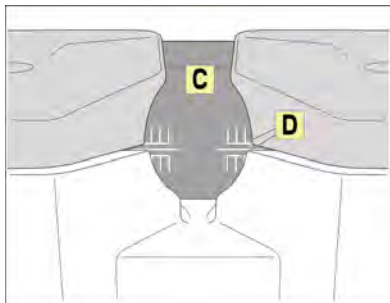

After adjustment, check that the wing mirrors do not come into contact with the windshield when turning the handlebar. Modify their positions if necessary.

Storage compartment / Accessory socket (USB / USBC)

An accessory socket fitted in the storage compartment, powered when the ignition is switched on, allows you to connect a mobile device (Telephone number, GPS, . . .)

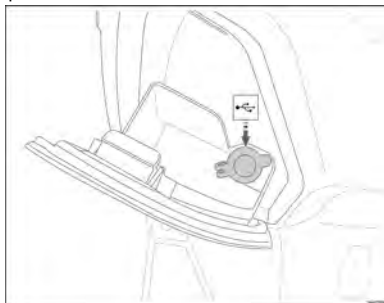

The equipment can recharge automatically during use.



Always replace the cap after use to prevent moisture from entering the socket.

Utility hanger

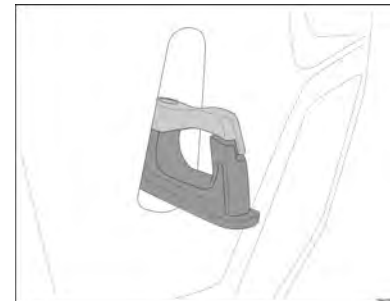

The utility hanger is located on the rear shield panel. It can be used to attach a maximum load of 2.5 kg.

Storage compartment



You are advised not to leave any objects in the storage compartments, whatever the value (helmet, document-holder, etc.), the manufacturer may not be held liable in the event of theft or intrusion.



Do not exceed the maximum load for the compartment, which is 5 kg. The seat compartment heats up as the engine heats up. Do not store food, flammable products or any products likely to be damaged by heat in the compartment.

As water can get into the compartment during washing or periods of heavy rain, you are advised to wrap in a bag any items to be stored in the compartment.

Do not store items that are too bulky in the compartment, as you risk damaging the items or the seat and its hinge.

Rear luggage carrier (Depending on model / Optional)



The rear luggage carrier can bear a maximum load of 7 kg.

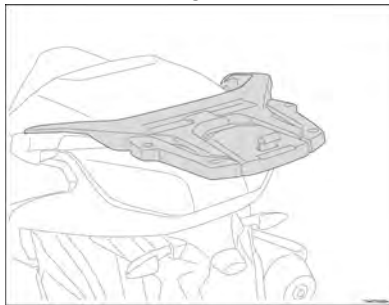

To not place luggage on it that is too bulky and may impair the lighting and steering.

Do not exceed the maximum recommended load for each luggage carrier.

Attach luggage firmly to the vehicle, even over a short distance.

Top case (Pulsion Evo Urban)



The top box is delivered with 2 keys.



The maximum permissible load for the top box is 5 kg.

Opening the top box:

- Insert the key into the lock.
- Turn the key to the left. The top box cover unlocks automatically.

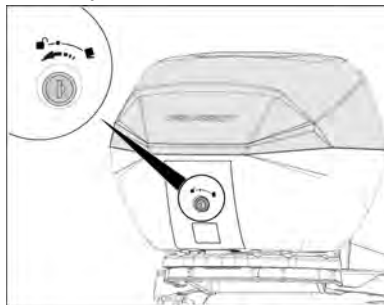

Closing the top box:

- Press on the cover to lock it.

Removing the top box:

- Insert the key into the lock.
- Turn the key to the right and press the button (A).
- Remove the top box and remove the key from the lock to avoid breaking it.

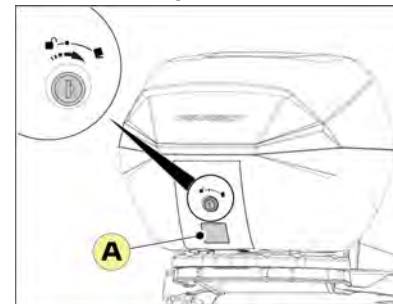

Fitting the top box:

- Insert the key into the lock.
- Turn the key to the right.
- Fit the top box to the front of the plate.
- Press the back of the top box to lock it onto the plate.
- Ensure it is securely locked on.
- Turn the key to position (o) and remove it.

Lateral stand

The stand is fitted with a contactor which will allow the engine to be started up if the stand is down but only with limited engine speed.



If the speed limitation does not work when the stand is unfolded, you are advised to go to an approved dealer to have this checked.

Adjustment of damper settings

Each damper has an adjuster ring that can be used to stiffen or soften the suspension, depending on the vehicle load.

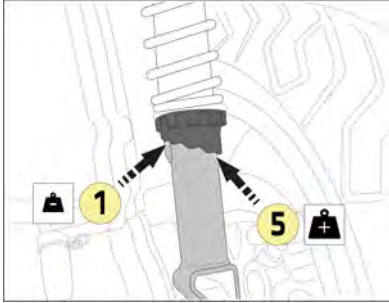

Adjustment of damper settings	Useful load: Driver + bags and/or passenger
Notch 1	< 80 kg
Notch 2 (Standard)	80 to 90 kg
Notch 3	90 to 100 kg
Notch 4	100 to 110 kg
Notch 5	> 110 kg



To guarantee your comfort and safety, always adjust the damper preload in line with the vehicle load.

Perform the same setting for the 2 dampers.

CHECKS TO PERFORM BEFORE USE

The user must personally ensure that his vehicle is in good condition. Certain safety elements may show signs of damage even when the vehicle is not used. e.g. prolonged exposure to bad weather can lead to oxidation in the braking system or a pressure drop in the tyres which can have serious consequences. In addition to a simple visual inspection, it is extremely important to check the following points before use.



These checks only take a few minutes and help to keep your vehicle in good condition, for optimum use combining reliability and safety.

If one of the elements in the checklist does not work properly, ask your registered dealer to check it and have it repaired if necessary before using the vehicle.

ADVICE FOR STARTING UP AND DRIVING

Warning

Before using the vehicle for the first time, make sure you are familiar with all the controls and their respective uses. If you are not sure about the functions of any of the controls, your registered dealer can answer your questions and give you any help you may require.



As exhaust fumes are toxic, the engine must be started in a well-ventilated area. It must never be allowed to run in a closed space, even for a short time.

Eco mode

Adopt smooth driving behaviour

- Turn the acceleration handle gradually, not suddenly.
- Anticipate braking using the engine brake.
- Limit the vehicle load as well as aerodynamic resistance.
- Regularly check the inflation pressure in your tyres, and refer to the label under the seat.
- Avoid heating up the engine while stationary: the engine heats quicker when you drive.
- Have your vehicle serviced according to the manufacturer's maintenance plan.

These attitudes contribute to economising fuel consumption, reducing CO² emissions and alleviating the background sound of traffic.

Driving on flooded roads



You are strongly advised not to drive on flooded roads as this may seriously damage the engine, transmission and electrical systems on your vehicle.

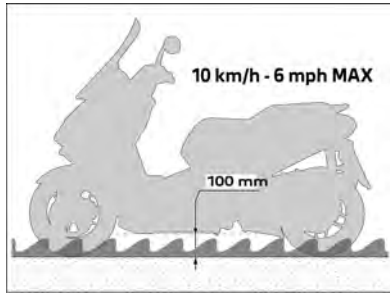

If you cannot avoid driving through flood water:

- Check that the water depth does not exceed 100 mm, taking into account waves which could be generated by other road users.
- Under no circumstances exceed a speed of 10 km/h.
- Once out of the flooded area, brake gently several times to dry out the brakes as soon as the safety conditions allow it.

Inspection before setting off

Component	Checks
Fuel	<ul style="list-style-type: none">• Check the fuel level in the tank.• Top up with fuel if necessary.• Check that there is no fuel leak.
Engine oil	<ul style="list-style-type: none">• Check the level of the engine oil.• If necessary, top up with the recommended oil.
Coolant	<ul style="list-style-type: none">• Check the coolant level in the header tank.
Disk brakes	<ul style="list-style-type: none">• Check brake operation.• Have an approved dealer check them if they feel soft.• Check brake pad wear.• Check the level of brake fluid in the reservoir.
Lighting, signalling, indicators, horn	<ul style="list-style-type: none">• Check operation.• Correct if necessary.
Wheels and tyres	<ul style="list-style-type: none">• Check the tyre wear and condition.• Check the tyre pressures cold.• Correct if necessary.
Throttle	<ul style="list-style-type: none">• Check the throttle handle turns smoothly and returns correctly to its starting position.
Steering	<ul style="list-style-type: none">• Check the free rotation of the steering.
Stand	<ul style="list-style-type: none">• Check that the central and side stands can be unfolded smoothly.• Operation of the ignition cut-out.

Starting the engine

For greater safety, place the vehicle on its central stand before starting the engine.

- Turn the ignition key to "ON". Wait for the end of the instrument panel self-test.
- Ensure that the throttle is in the OFF position.
- Press one of the brake levers while pressing the starter button. Do not press the starter for more than 10 seconds.
- Release the starter button as soon as the engine starts.



If the engine does not start, release the starter button and the brake lever, wait a few seconds and try again. Each attempt to start the engine should be as short as possible to save the battery.



To avoid any accident, do not leave the vehicle unattended while the engine is running.

Driving

Starting off



Warm up the engine for a few seconds before setting off

- The vehicle is on its stand with the engine running.
- Squeeze the brake lever with your left hand, grip the grab handle with your right hand and push the vehicle forwards to fold up the central stand.
 - Sit on the vehicle.
 - Release the left brake and turn the throttle slowly with your right hand to start moving.

Accelerating and decelerating

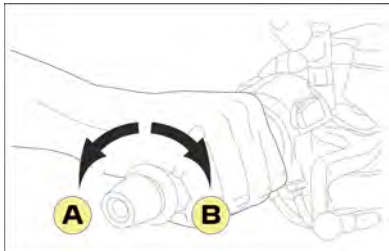

To accelerate, turn the throttle towards (A). To slow down, turn the throttle towards (B).



For your safety and that of the vehicle, ride onto or off pavements facing straight at the kerb and at very low speed, with the handlebars and wheels straight. Preferably get off the vehicle to do so.

Braking system

ABS Braking system

This is a wheel anti-lock system.

- The anti-lock braking system (ABS) is designed to prevent the wheels from locking up during braking.
- The ABS system enables the rider to retain control of the vehicle when braking in slippery conditions.
- To be more effective, use the front and rear brake at the same time and in the same way.

The ABS system is not active when the vehicle speed is less than or equal to approximately 5 km/h.

The ABS system does not work if the battery is flat.

Use of the brakes

- Close the throttle.
- Activate the brake system by gradually increasing the pressure.



Avoid braking suddenly on wet roads or in bends. The vehicle may skid and fall over.

Manhole covers and road markings become extremely slippery when wet. Slow down before riding over this type of surface and be vigilant when crossing them.

Reduce speed on steep slopes to avoid prolonged braking, as overheating will reduce braking efficiency.

Switching off the engine and parking

The engine is switched off when at idling speed by turning the ignition key to "OFF".

The vehicle should be parked on flat ground.

- Either on the middle stand.
- Or on the lateral stand.



Each time the vehicle is parked, the steering should be locked and the ignition key removed.

Fuel supply



The engine must be switched off in order to fill the fuel tank in complete safety.



A label affixed near the fuel cap reminds you of the type of fuel to use.



Any fuel containing up to 10% ethanol can be used (E5, E10).

An ethanol content of more than 10% by volume is not permitted. E85 must not be used.

- Place the vehicle on the central stand.

- Open the fuel flap.

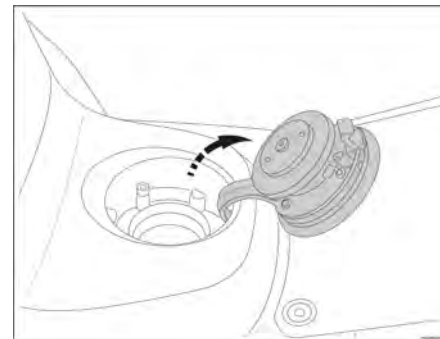

- Insert the petrol pump nozzle into the filling orifice. Make sure the nozzle is correctly inserted into the filling pipe.
- Fill the tank to the lower end of the filler tube and not beyond it.

Stop filling when the nozzle stops for the first time.

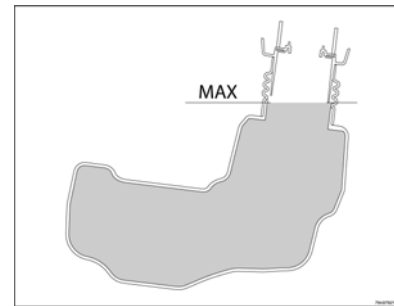

Do not fill the fuel tank to excess: The fuel may expand due to the engine heat or heat from the sun and overflow.



Any overflows must be wiped up immediately. The fuel could actually damage painted surfaces or plastic parts.

GB

Running in the engine

Running in the engine is essential to guarantee its performance and lifetime.

During the running-in period, you are advised not to overload the engine and to avoid exceeding a higher than normal operating temperature.

From 0 to 500 km:	<ul style="list-style-type: none">• Do not hold the throttle handle open at more than half its distance of travel over a long trip.
From 500 to 1000 km:	<ul style="list-style-type: none">• Do not hold the throttle handle open at more than 3/4 its distance of travel over a long trip.

Once this mileage has been done, the vehicle can be used normally.

SERVICE OPERATIONS

Maintenance advice

Ensure the servicing schedule for your vehicle is strictly adhered to in order to maintain warranty rights.

A table of inspections for the maintenance schedule is inserted into the maintenance booklet. The registered dealer must add his stamp, the date of servicing and the number of kilometres the vehicle has covered.

In order to maintain maximum safety and reliability of your vehicle, you are advised to have maintenance and repairs carried out by a registered dealer who has the necessary technical training, specific tools and spare parts.

Environment / Recycling

Worn parts replaced during routine maintenance (mechanical parts, battery, etc.) must be disposed of with specialised bodies.

At the end of its life, the vehicle must be taken to an authorised centre for recycling.

In all cases, comply with the local laws.



Batteries contain harmful substances. They must be disposed of according to the legal requirements and must under no circumstances be thrown away in the household waste.

Cleaning the vehicle



The bodywork is made of plastic parts that can be painted or are shiny. Do not use solvents or cleaning products that are too corrosive.



Do not use high pressure cleaners which may cause water to infiltrate the following parts: seals, bearings and hinges, electrical components such as connectors, contactors and lighting.

Wash the bodywork with soapy water and rinse with generous amounts of clear water.

The vehicle can be dried with a chamois leather. After washing the vehicle, brake several times at low speed to dry out the brakes.



The vehicle should be washed in a place equipped for wastewater collection.

Certain silicon-based products can alter the quality of the paintwork. In case of need or doubt, a registered dealer can advise you on using cleaning products or restoring scratched bodywork.

Spark plug inspection or replacement



It is essential to use a resistive spark suppressor and a resistive spark plug in accordance with the manufacturer's recommendations.

We advise you to visit a registered dealer for the replacement of these components.

The engine must be cold.

- Lift the seat and remove the storage compartment.
- Disconnect the suppressor (1).
- Remove the spark plug.

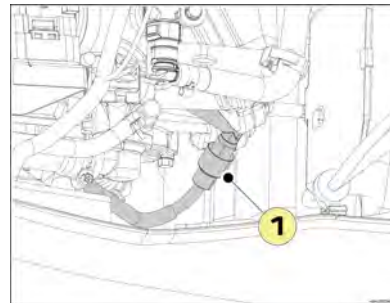

- Measure the electrode spacing and correct it if necessary (A).

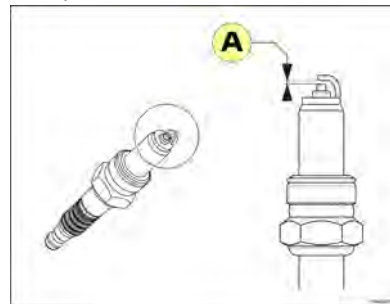

Spark plug
NGK CPR8EB NGK CPR9EB
Electrode gap
0.7 to 0.8 mm
Tightening torque
12 Nm

- Fit and screw in the spark plug manually.
 - Tighten to the recommended torque.
- If not tightening using a torque wrench, tighten according to the following method:
- 1/8 - 1/4 turn for a reused spark plug.
 - 1/2 turn for a new spark plug.



Ensure the suppressor is correctly clipped onto the spark plug.
Have the torque quickly checked by a registered dealer.

Checking the engine oil level



Check the oil level every 1000 km / 600 Mi or before a long journey.
Any supplementary oil used must be oil recommended by the manufacturer.
Too much oil will noticeably restrict the vehicle's performance.

Level check.

- To correctly measure the oil level, place the vehicle on the centre stand on flat ground.
- Start the engine, let it run for a few minutes and then stop it.
- After switching off the engine, wait for 5 minutes to allow the engine oil time to return to the oil sump.
- Remove the oil filler cap/gauge (1).

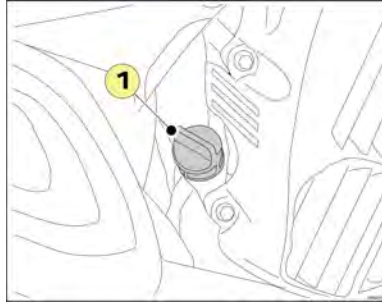

- Wipe the filler cap/gauge using a clean cloth and reinsert it into the filler hole without screwing it up.

- Remove the filler cap/gauge and check the oil level.
- The oil level shall be between the minimum (A) and maximum (B) level marks without exceeding the latter.

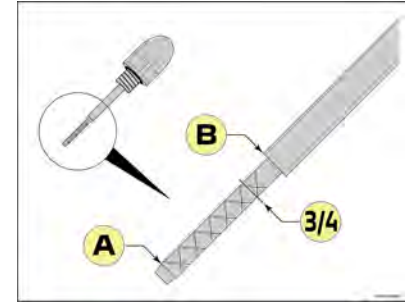

- If the oil level is close to the minimum mark or lower, you are advised to immediately top up the level to 3/4 in small amounts using the oil recommended by the manufacturer.

Changing the engine oil



We advise you to go to a registered dealer for draining.



Oil contains substances which are harmful to the environment. Your dealer is equipped to dispose of used oil without endangering the environment and in compliance with current standards.

Engine oil

SAE 5W50 synthetic API SN

Quantity:

0.8 l at oil change

The engine must be drained when it is warm to allow the oil to run easier.

- Place the vehicle on its central stand on flat ground.
- Put on protective gloves.
- Remove the cap/oil gauge.
- Remove the drainage cap and its seal (2) and allow the oil to drip into a recipient.

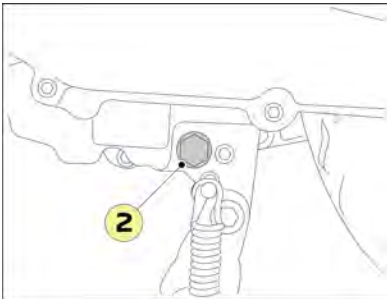

- Put back the drainage cap, fitted with a new seal (Tightening torques: 38 Nm).

- Remove the strainer cap (3) and clean the strainer (4).

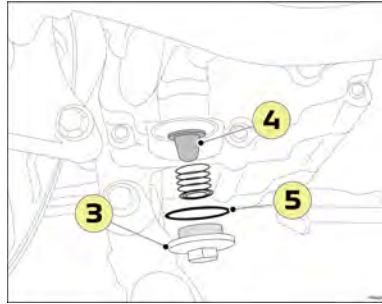

- Install the strainer and its cap fitted with a new seal (5) (Tightening torques: 15 Nm).
- Pour the required quantity of oil corresponding to the manufacturer's standards into the filler hole.
- Start the engine and let it run for a short while.
- Remove the filler cap/gauge and check the oil level.
- Add oil if necessary.
- Check that the oil drain plug is sealed.

Draining the relay box



We advise you to go to a registered dealer for draining.



Oil contains substances which are harmful to the environment. Your dealer is equipped to dispose of used oil without endangering the environment and in compliance with current standards.

The gearbox must be drained when the engine is warm so that the oil will run easier.

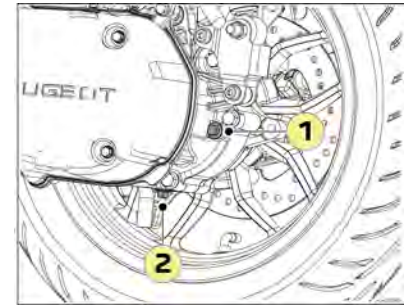

- Place the vehicle on its central stand on flat ground.
- Place a container under the drain port.
- Remove the relay box filler cap (1).
- Remove the drain plug (2).
- Re-install the plug with a new seal (Tightening torque: 10 Nm).
- Pour the required quantity of oil corresponding to the manufacturer's standards into the filler hole.
- Fit the filler cap (Tightening torque: 10 Nm).

Relay box oil

SAE 80W90 API GL4

Quantity

0.17 l at oil change

Coolant



Check the coolant liquid level before setting off each time.

Any supplementary coolant used must be coolant recommended by the manufacturer.

The coolant level must be checked when the engine is cold.

Level check.

- Place the vehicle on its central stand on flat ground.
- Remove the access door.

The level of coolant should be between the minimum and maximum markers without exceeding the latter.

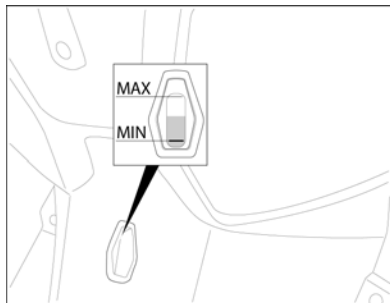

Adjust the level as follows if it is equal to or less than the minimum level marked:

- Remove the technical access door (Right side).

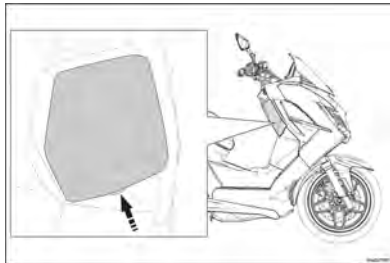

- Remove the expansion tank cap (1).



- Add the coolant level up to the specified level.

Replacing the air filter

- Remove the air filter cover.
- Remove the air filter.
- Clean inside the air filter box.
- Check the condition of seals. Change if necessary.
- Fit a new air filter.
- Re-fit the cover.
- Remove the drain plug of the intake silencer to drain moisture and oil (1).

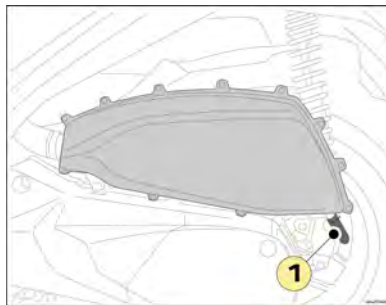

Throttle cable play

Throttle play must be between 3 and 5 mm at the handle (A).

If play is not correct, use the setting screw to adjust it (1).

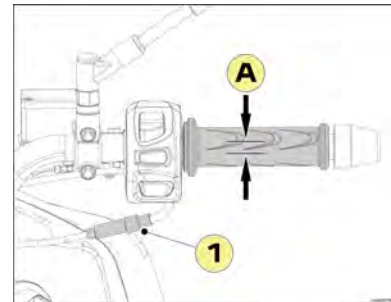

Tyres

Tyre pressure should be cold-checked regularly. Incorrect pressure causes abnormal wear and affects road behaviour, thus making driving dangerous.

	Front	Rear
Solo	2.2 bars	2.4 bars
Pillion	2.2 bars	2.6 bars

If the wear limit on the tread is reached (A), you are advised to go to a registered dealer to change the tyres.

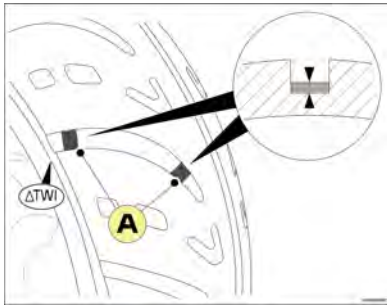

When replacing tyres, you are advised to mount tyres of the same brand and equivalent quality. In case of puncture, it is forbidden to mount an inner tube in a tubeless tyre.



Tyres contain substances that are harmful to the environment. Your dealer is equipped to dispose of used tyres without endangering the environment in compliance with current standards.

Brake inspection



We advise you to visit a registered dealer for the replacement of these components.

Each brake pad is equipped with wear indicators (A). The indicators enable you to check the wear on the pads without having to disassemble the brake. Check the wear on the pads by verifying the position of the wear indicators while depressing the brake. If a brake pad is worn to the point that the indicator touches the brake disk, have the pair of brake pads replaced by an approved distributor.

Front brake pad wear

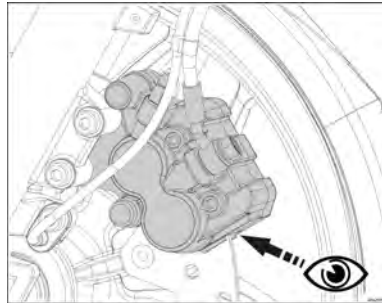

Rear brake pad wear

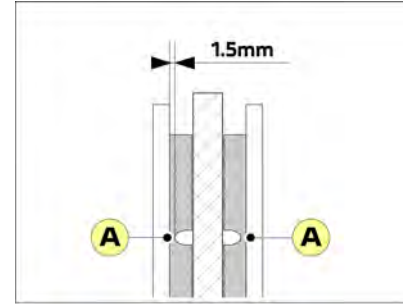
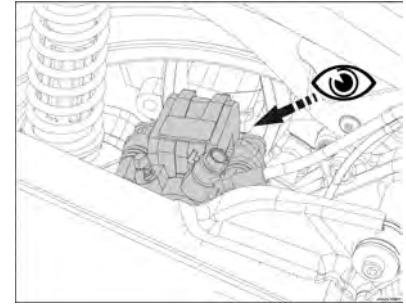

A. Wear indicators

Brake fluid

The brake fluid levels must be checked regularly through the braking unit inspection window .



Before verifying the liquid level, ensure that the reservoir of the brake master cylinder is horizontal.

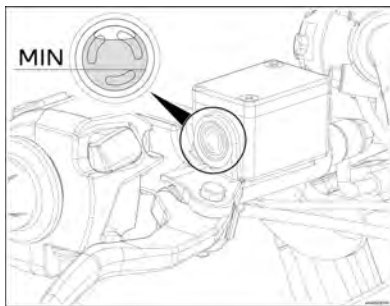

If the level is near the minimum mark, it is advisable to take the vehicle to an approved dealer as soon as possible to check the brake system and refill it if necessary.

Brake fluid

DOT 5.1

Battery



Make sure you check that the battery is disconnected before performing any operations on it.



Battery power leads must never be disconnected while the engine is running.
To avoid damage to the electronic circuit, do not charge the battery if it is connected to the vehicle.



The sulphuric acid contained in the battery electrolyte can cause serious burns.
Avoid all contact with the skin, eyes or clothing and always protect your eyes when working near the battery.



In case of leakage, you are advised to consult a registered dealer who is equipped to replace and dispose of batteries without endangering nature and the environment.



A battery produces explosive gases.
Keep the battery away from sparks, flames, cigarettes, etc.
It should be charged in a well-ventilated area.

Extended periods of immobilisation and storage



If the vehicle is not used for an extended period, the battery will slowly discharge naturally or due to its electronics or certain accessories and must thus be regularly charged.

- If the vehicle is not used for a period of 1 month or longer, the battery charge must be preserved.
- Using a maintenance charger (if the vehicle is not used for a long period).
 - If not, by disconnecting it from the vehicle (if the vehicle is not used for a period of less than 2 months).



If these recommendations are not followed, the battery may go into deep discharge. In this case the manufacturer's warranty will be void.

Battery charge



A battery produces explosive gases. Keep the battery away from sparks, flames, cigarettes, etc..
It should be charged in a well-ventilated area.



The battery must be charged in a well-ventilated area with a suitable charger that can feed a tenth of the battery capacity to avoid premature destruction. You are therefore advised to go to a registered dealer to carry out this operation.



To avoid any risk of destruction of an electrical component, you are strongly advised not to use a booster charger to start the vehicle.

- Disconnect and remove the battery.
- Charge the battery to 100% beforehand.
- Use a maintenance charger or charge monthly.
- Before restarting, the battery must be charged to 100%.

Removal of the battery

- Turn off the ignition.
- Remove the battery access door.
- Remove the retention strap.
- Disconnect the positive terminal of the battery (1).



- Gently remove the battery from its housing to disconnect the negative terminal (2).

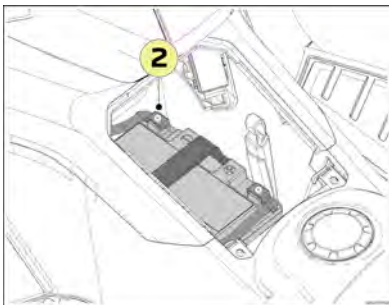

Installing the battery

- Fit the battery into its housing.

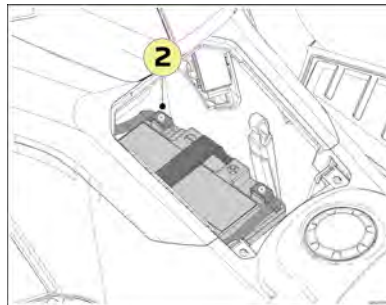

- Connect the negative terminal to the battery (2).



- Connect the positive terminal to the battery (1).
- Fit the retention strap.
- Fit the battery access hatch.

Headlight adjustment

The headlight is adjusted using a screw located under the headlight.

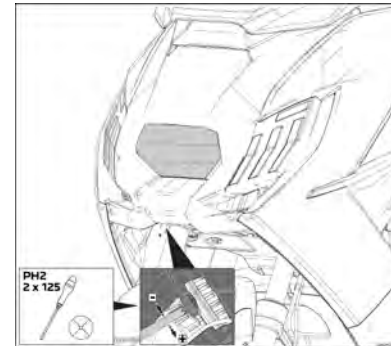

Fuses

The electrical system is protected by fuses placed near the battery. (fuses from F1 to F10)

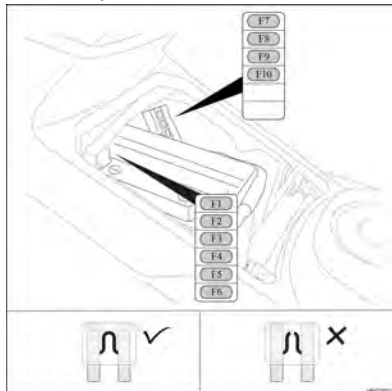

If a fuse often blows this is usually a sign of a short circuit in the electrical circuit. You are advised to have the system checked by a registered dealer. Find the faulty fuse by looking at the condition of its filament.



Before changing a fuse, you must find the reason for the fault and correct it. You are advised to switch off the ignition before changing a fuse and always to replace it with a fuse of the same rating. If you do not do so, this may lead to damage in the electrical circuit or even a fire.

Fuse allocation

F1 3A	General supply
F2 10A	Instrument panel OBD socket
F3 20A	Regulator
F4 3A	USB socket
F5 15A	Injection system OBD socket ABS Direction indicators
F6 15A	Injection system
F7 20A	Fuel pump
F8 10A	Injection system
F9 20A	ABS
F10 15A	Lighting Direction indicators

Peugeot Motocycles recommends



Quality management system certified ISO
9001 by UTAC



Peugeot Motocycles SA
Rue du 17 Novembre
F-25350 Mandeure

Tél. +33(0)3 81 36 80 00

RCS Belfort B 875 550 667

www.peugeot-motocycles.fr
www.peugeot-motocycles.com



Dans un souci constant d'amélioration Peugeot Motocycles se réserve le droit de supprimer, modifier ou ajouter toutes références citées.
DQ/APV du 02/2024 (photos non contractuelles).



PEUGEOT

MOTORCYCLES



GUIDE D'UTILISATION EN LIGNE
ONLINE USER'S GUIDE