

# PEUGEOT MOTORCYCLES



**PEUGEOT**  
MOTORCYCLES

## **PEUGEOT METROPOLIS**

Notice d'utilisation  
User's manual



Owner's manual





**TABLE OF CONTENTS**

Information..... 1  
 Safety advice..... 1  
 Characteristics..... 2  
 Vehicle identification..... 5  
     Products to use..... 5  
 Information about the instructions..... 6  
 Description of the vehicle..... 7  
 Controls..... 8  
 Instruments..... 10  
     Warning lights..... 10  
 List of warning lights..... 11  
 Digital display..... 14  
 "Personalisation - Configuration" menu..... 15  
     The functions which can be accessed via the configuration menu are described in detail in the table below..... 16  
 Connectivity menu (Depending on model) (i-Connect)..... 19  
     Pair a Bluetooth® telephone (Depending on model)..... 19  
     Digital display (Depending on model)..... 19  
 Mobile app..... 20  
 Creating the account..... 20  
     Forgotten password..... 20  
     Pair a Bluetooth® telephone..... 21  
 Homepage..... 22  
 "NAVIGATION" page..... 23  
 "DASHBOARD" page..... 24  
 "Settings" page..... 25  
 smart key key, rotating knob and openings..... 27  
     smart key key..... 27  
     Rotating knob..... 27  
     No smart key recognition..... 29  
     Replacing or adding a smart key..... 29  
 Openings..... 29  
 Equipments..... 30

Adjusting the handlebar (Version GT)..... 30  
 Rear storage compartment..... 31  
 Checks to perform before use..... 34  
 Advice for starting up and driving..... 34  
     Warning..... 34  
     Eco mode..... 34  
     Driving on flooded roads..... 34  
     Inspection before setting off..... 35  
     Starting the engine..... 35  
     Driving..... 35  
     Braking..... 35  
     Fuel supply..... 36  
     Running in the engine..... 36  
     Stopping the vehicle and parking..... 36  
 Repair procedures..... 37  
     Procedure for opening storage compartments... 37  
     Procedure for manual unlocking of the anti-tilting system..... 37  
     Procedure for manual unlocking of the parking brake..... 38  
 Service operations..... 39  
     Maintenance advice..... 39  
     Environment / Recyclable..... 39  
     Cleaning the vehicle..... 39  
     Spark plug inspection or replacement..... 39  
     Engine oil level..... 40  
     Changing the engine oil..... 40  
     Replacing the oil filter..... 41  
     Coolant level check..... 41  
     Air filter element..... 41  
     Throttle cable play..... 42  
     Tyres..... 42  
     Brake inspection..... 42  
     Battery..... 43  
     Fuses..... 44  
     Bulb replacement..... 45

Headlight adjustment..... 45

GB

## INFORMATION

You have just bought a Peugeot vehicle.

We would like to thank you for purchasing one of our products.

Please take some time to read this manual carefully before using the vehicle.

This user manual should always be kept in the boot of the vehicle. It contains instructions for use, checks and maintenance of the vehicle, and important safety instructions intended to protect the user and third parties against accidents.

It will give you plenty of advice on how to keep your vehicle in full working order.

Your authorised dealer is familiar with all the vehicle's characteristics and has genuine spare parts and specific tools. He can advise you and service your vehicle in the best conditions according to the established service schedule to ensure that you can enjoy driving it in complete safety.

This manual must be considered as an integral part of the vehicle and must remain with it even if the vehicle is sold on.

PEUGEOT MOTOCYCLES is constantly improving its vehicles. It therefore reserves the right to remove, modify or add any reference mentioned.

## SAFETY ADVICE

A inexperienced motorcyclist should make himself completely familiar with his vehicle before going out in traffic. You are strongly advised not to lend your vehicle to an inexperienced rider.

To ride a motorbike, you are required by law to hold a licence or to have completed specific training with a professional, depending on the applicable legislation and based on its category.

Wearing an approved helmet and gloves is obligatory for the user and passenger. You are also advised to wear goggles and light-coloured or reflective clothing adapted to motorcycling.

In some countries, the applicable legislation may not authorise transportation of a passenger, and elsewhere it may oblige motorcycle users to contract a civil liability insurance policy to protect third parties and the passenger against potential damage resulting from an accident.

Driving whilst under the influence of alcohol, drugs or certain medicines is inexcusable and dangerous for yourself and others.

Excessive speed is an important factor in many accidents. You must observe the road signs and signals and adapt your speed to the weather conditions.

The engine and the exhaust system components can reach very high temperatures. When parking your vehicle, be careful to avoid contact with inflammable materials which could cause a fire or with parts of the body which could result in serious burns.

Luggage carriers and panniers approved by PEUGEOT MOTOCYCLES are available as options (depending on the model). The assembly instructions must be complied with and the maximum permissible load (3 to 5 kg depending on the equipment) must not be exceeded.

Fitting accessories such as the driver's apron, top-case, etc. may affect the vehicle's stability (wind factor, load, etc.).

When riding the vehicle fitted with accessories, the driver should reduce speed.

Mounting adaptable parts that have not been approved by PEUGEOT MOTOCYCLES, which alter the technical characteristics or performances of the vehicle is forbidden. Any modification will invalidate the warranty and the vehicle will no longer be in compliance with the version approved by the appropriate services.

GB

## CHARACTERISTICS

		METROPOLIS
Official type-approval code		X1AADB
Weight in kg		
Unladen weight		264
In working order		280
Authorised maximum. Total weight of the vehicle, the user, the passenger, the accessories and luggage.		455

### Dimensions in mm

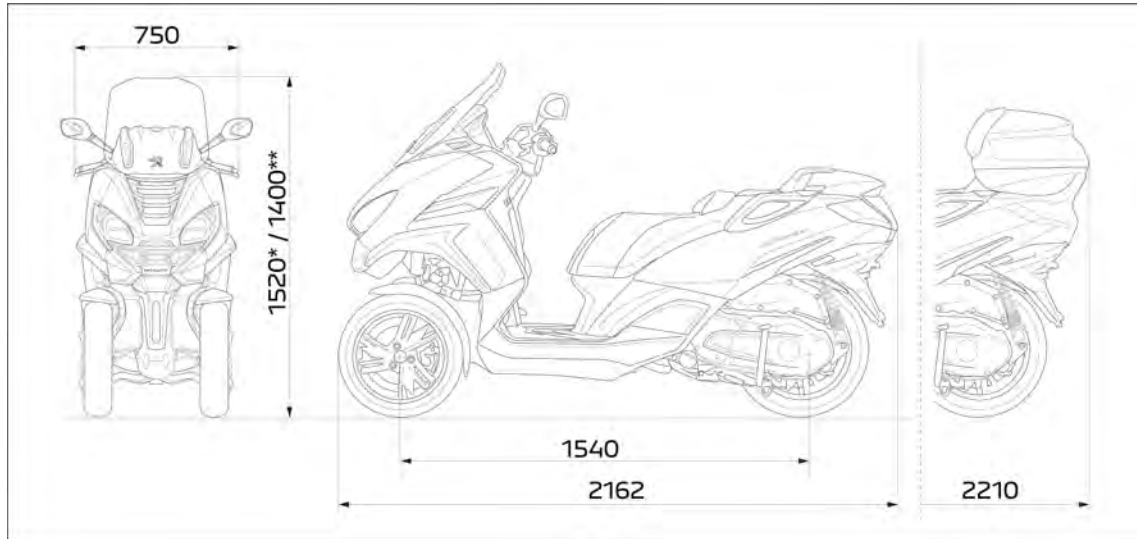

\* Large windshield, high position.

\*\* GT version windshield, high position.

	METROPOLIS
Engine	
Identification	P6F
Engine type	4-stroke single-cylinder
Cubic capacity	400
Bore x stroke in mm	84 X 72
Maximum power	26.2 kW at 7250 rpm
Maximum torque	38.1 Nm at 5750 rpm
Cooling	Fluid cooling system
Fuel supply	Indirect electronic injection
Spark plug	NGK CPR8EB-9
Lubrication	Pressurised wet sump lubrication
Exhaust	Catalytic
Anti-pollution standard	Euro 5+
Consumption <sup>1</sup>	3.9 l/100
CO2 emission (On cycle)	89 g/km

<sup>1</sup> These consumption values are established according to Regulation 134/2014 Appendix VII. They may vary according to driving behaviour, traffic conditions, weather conditions, the load in the vehicle, vehicle maintenance and use of the accessories etc.

		METROPOLIS
<b>Capacities in litres</b>		
Engine oil		
• Without oil filter replacement		1.8
• With oil filter replacement		2
Relay box oil		0.25
Coolant		2
Fuel tank		12.8
<b>Tyre dimensions</b>		
Front		110/70-13
Minimum load index and speed rating		27 N
Rear		140/70-14
Minimum load index and speed rating		66 N
<b>Cold inflation pressure (bar)</b>		
Front		2
Rear		2.5
<b>Suspension</b>		
Front		Deformable parallelogram with double wishbone (Dual Tilting Wheels (DTW)) Single shock absorber. Travel: 120 mm
Rear		Adjustable shock absorbers Travel: 103 mm
<b>Brakes</b>		
Braking system		Integral braking
Front		2 Ø230 disks
Rear		1 Ø240 disk
<b>Electrical equipment</b>		
Headlights		LED
Rear light		LED
Number plate light		12V - 5W
Storage compartment lighting		12V - 5W
Battery		Maintenance-free batteries 12V - 18Ah BS-BATTERY BTX20CH

## VEHICLE IDENTIFICATION

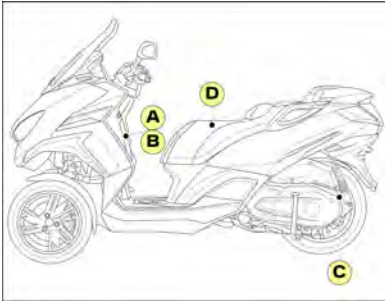

- A** Manufacturer's plate.
- B** Vehicle identification number (V.I.N).  
Located in the glove compartment, the plate and identification number are visible after removing a hatch.
- C** Engine number.
- D** Tyre pressure label.  
The label affixed under the saddle gives the cold tyre pressures when riding alone and with a passenger.

✓ Temperature variations modify tyre pressure.  
The tyre pressure must be checked once a month when cold.

## Products to use

### Fuel

Exclusively: Unleaded E5 or E10



### 4 stroke engine oil

SAE 5W40 100% synthetic  
Minimum grade API SN

### Relay box oil

SAE 80W90 API GL4

### Grease

High-temperature grease  
Multi-use grease

### Brake fluid

Brake fluid DOT 5.1

### Coolant

Coolant: MOTUL. Type C  
Anti-corrosion and anti-freeze,  
Protection -37°C/-35°F  
Nitrite free / Amine free / Phosphate free

# MOTUL

## INFORMATION ABOUT THE INSTRUCTIONS

Specific information is indicated by the following symbols:



Möbius band  
Recyclable.  
Means that the product or the package can be recycled.



Explosive  
The product may explode upon contact with a naked flame, spark or static electricity, or due to the effect of heat, an impact or friction.  
Handle and keep away from heat sources and other causes of sparks.



Flammable  
The product may ignite in contact with a naked flame, a spark or static electricity, in contact with the air or in contact with water, releasing inflammable gases.  
Handle and keep away from heat sources and other causes of sparks.



Corrosive  
The product is corrosive.  
It can attack (corrode) or destroy metals.  
Contact with the product or splashes of the product may burn the skin and cause lesions to the eyes. Avoid any contact with the eyes and skin. Do not inhale.



Harmful to health  
The product can be poisonous in high doses.  
It may irritate the skin, eyes and airways.  
It may cause skin allergies.  
It may cause drowsiness or dizziness. Avoid all contact with the product.



Toxic or fatal  
The product can rapidly be fatal.  
It poisons rapidly, even at low doses. Wear protective equipment.  
Avoid any contact (oral, skin, inhalation) with the product and wash all exposed areas carefully after use.



Harmful for the environment  
The product pollutes.  
It has a harmful effect (in the short and/or long term) on organisms in aquatic environments.  
Do not dispose of it in the environment.



Do not throw away into a garbage can  
One of the product's component is toxic and can be hazardous to environment. Do not throw the used product in the dustbin. Take it back to the trader or to a specific waste disposal site.



People's safety  
Operation that can be dangerous for people.  
People's safety can be seriously affected if the recommendations are not fully respected.



Important  
Operation that can be hazardous to the vehicle.  
Indicate the specific procedures that shall be followed in order not to damage the vehicle.



Note  
Gives key information concerning operation of the vehicle.

## DESCRIPTION OF THE VEHICLE

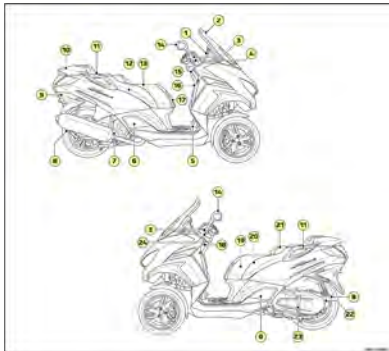

1. Instrument panel
2. Adjustable windshield
3. Brake fluid level
4. Right brake lever
5. Brake pedal (integral main brake)
6. Folding passenger footrests
7. Engine oil gauge
8. Adjustable shock absorbers
9. Emergency storage compartment opening control
10. Rear storage compartment
11. Passenger saddle and grab handle
12. Front storage compartment
13. Rider saddle
14. Aspherical rear view mirrors
15. Coolant level
16. Glove box / Chassis markings / Manufacturer's plate
17. Utility hanger
18. Storage compartment / USB socket / Emergency antenna

19. Fuel tank cap
20. Battery / Fuses
21. Adjustable backrest
22. Engine number
23. Central stand
24. Left brake lever

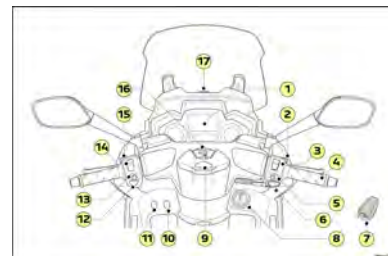

1. Instrument panel
2. "SELECT" selection button
3. Light button
4. Throttle
5. System control Anti-tilting
6. Starter switch / Emergency stop button
7. Smart-Key key
8. Rotating knob
9. Hazard warning lights switch
10. Unlocking control for front storage compartment
11. Unlocking control for rear storage compartment
12. Horn switch
13. Indicators switch
14. Code button / Headlight / Flashing the lights
15. "EXIT" selection button
16. Parking brake control
17. Attachment for Smartphone bracket (Accessory)

GB

Right controls.

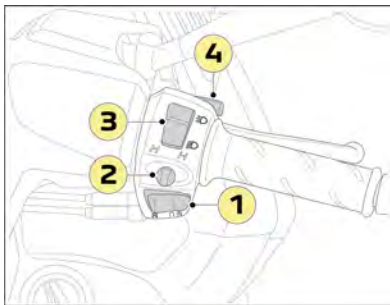

GB

**1. Emergency stop button/Starter switch.**

- ✘ Set the button to this position in case of emergency to stop the engine.
- ☾ Set the button to this position before starting the engine.
- ⚡ Press this button and simultaneously press the right or left brake lever to start the engine.

**2. System switch for Anti-Tilting.**

For handling purposes, the vehicle has a hinge on the front wheels allowing the two front wheels to tilt while remaining parallel when taking a bend.

The Anti-Tilting system is used to lock this hinge and thus stabilise the vehicle when it is moving at slow speed or park the vehicle without using the stand.

☑ Push the switch to this position to lock the front axle. The warning light comes on with the emission of a long beep.

☑ Push the switch to this position to unlock the front axle. The warning light goes off with the emission of 2 beeps.

**Conditions for locking the front axle manually**

- The speed of the vehicle must be less than 11 km/hour and the engine speed under 2800 rpm when the switch is set to the locking position.

**Conditions for automatic unlocking of the front axle**

- The front axle is automatically unlocked if the speed of the vehicle is greater than 11 km/hour and/or the engine speed greater than 2800 rpm.

**Manually unlocking the front axle**

- Outside the conditions for automatic unlocking, set the switch to the unlocking position.



Unlocking the front axle may lead to the vehicle falling over. If the vehicle is stopped with the rotating knob set to the "on" position, do not operate the throttle (engine running) or the Anti-Tilting switch if the stability of the vehicle is not under control.



The parking brake and the Anti-Tilting might not hold the vehicle upright in all situations: Load on the vehicle, steep slope, prolonged immobilisation etc. Preferably park the vehicle on the central stand.

**3. Lighting switch/Daytime lights (DRL).**

- ☑ With the ignition on, push the switch to this position. The daytime lights are on.
- ☑ With the ignition on, push the switch to this position. The daytime lights and dipped lights are on.



The daytime lights switch off automatically 15 seconds after the ignition is switched off.

**4. "SELECT" selection button.**

This control enables:

- Access to the connectivity menu<sup>1</sup> (Press and hold for 2 seconds).
- Navigation within the menus (exiting a menu).
- Confirmation of a choice (Press and hold for 2 seconds).

See chapter: "[Personalisation - Configuration menu](#) page 15 .

<sup>1</sup> Depending on model

## Left controls.

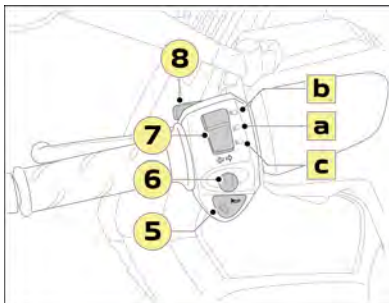

### 5. Horn switch.

### 6. Indicators switch.

To indicate a change of direction, press the switch:

- Either to the right.
- Or to the left.

To stop the indicators flashing, press the switch.

### 7. Dipped light switch / High beam / Flashing the lights.

The dipped lights and main beams only operate if the lighting switch on the right handlebar is in position .

- ☞ a. Push the switch to this position to switch on the dipped lights.
- ☞ b. Push the switch to this position to switch on the main beams.
- ☞ c. Press this button to flash the headlights.



The presence of mist on the inside of the headlight glass is normal. It disappears a few minutes after the lights are switched on.

### 8. "EXIT" selection button.

This control enables:

- Access to the instrument panel personalisation menu (Press and hold for 2 seconds).
- Navigation within the menus (exiting a menu).
- Confirmation of a choice (Press and hold for 2 seconds).

See chapter: "[Personalisation - Configuration](#)" menu page 15 .

## Central controls.

### Standard version

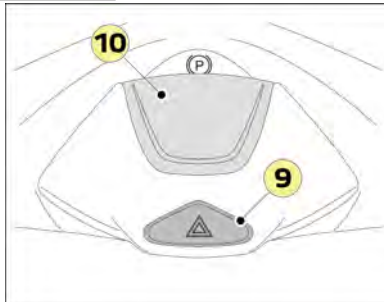

### Version GT

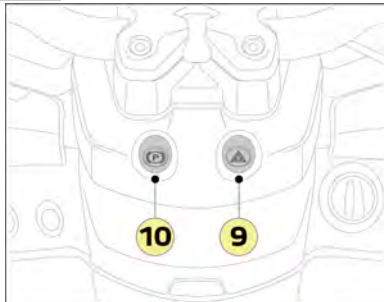

### 9. Hazard warning light switch.

The hazard warning lights can only be switched on with the ignition in the "ON" position.

The hazard warning lights are automatically deactivated 1 hour after the ignition is switched off to save the battery.

### Automatic activation of hazard lights.

The hazard lights will activate automatically during emergency braking, depending on the force of deceleration. They will automatically switch off upon acceleration.

### 10. Electric parking brake button.

Apply moderate pressure to the button to activate/deactivate the parking brake.



Do not force when the button is pressed as far as it can go.

### Conditions for activation of the parking brake.

- The speed of the vehicle must be less than 3 km/h.



The warning light comes on on the dashboard to indicate that the parking brake is active.



Always engage the electric parking brake each time the vehicle is parked.



The parking brake and the Anti-Tilting might not hold the vehicle upright in all situations: Load on the vehicle, steep slope, prolonged immobilisation etc. Preferably park the vehicle on the central stand.

## INSTRUMENTS



### 1. Digital display (I-CONNECT).

You can change the appearance of the handset by selecting:

- A display colour.
- A background colour.
- The display of certain information (See chapter: "[Personalisation - Configuration](#)" menu page 15).

### 2. Analogue speedometer.

- The speedometer has a dual display (km/miles).

### 3. Revolution counter.

- The analog rev counter shows the speed of rotation of the engine.

### 4. Area displaying the warning lights / Operating lights.

### 5. Brightness sensor.

(See chapter: "[Personalisation - Configuration](#)" menu page 15).

## Warning lights

The warning lights inform the driver of the start-up of a system or appearance of a malfunction.









- On ignition, some warning lights are displayed for a few seconds.
- Once the engine is started, these warning lights will disappear.

**If they remain on, use the table to check the relevant warning light before driving off.**













The ABS system ON warning light disappears when the vehicle starts to move.

## LIST OF WARNING LIGHTS

Indicator	Status	Cause	Actions / Observations
 Left indicators	Flashing	The indicator control is activated to the left.	If the warning light flashes quickly, there is a fault in the direction indicators.
 Right indicators	Flashing	The indicator control is activated to the right.	If the warning light flashes quickly, there is a fault in the direction indicators.
 Hazard warning lights	Flashing	The hazard warning lights control is activated.	The left and right direction indicators, as well as their associated warning lights, flash simultaneously. Automatic cut out after 1 hour to preserve the battery. Automatic triggering of the hazard lights during emergency braking.
 Dip beam	Fixed	The lighting control is in the "dipped-beam headlamps" position.	
 High beam	Fixed	The lighting control is in the "main-beam headlamps" position.	
 Emissions control system failure warning light / Engine self-diagnostic	Fixed	The anti-pollution system is faulty.	You are advised to have the vehicle checked by an authorised dealer.
	Flashing	The engine control system is faulty.	You are advised to have the vehicle checked by an authorised dealer.
 Wheel anti-lock system (ABS)	Fixed	The ABS system is faulty.	The vehicle has a standard braking system. Drive carefully at moderate speed and have the vehicle checked by an authorised dealer.
 Deterrence light	Flashing	The ignition is switched off, the anti-theft deterrence system is active.	The warning light flashes for 1 minute.
	Fixed	The immobiliser system is faulty.	Impossible to start the engine. You are advised to have the vehicle checked by an authorised dealer.

GB

Indicator	Status	Cause	Actions / Observations
Ⓜ Anti-Tilting light	Off	The anti-tilting system is unlocked.	The front axle locking conditions are not met.
	Fixed	The anti-tilting system is locked.	The front axle is automatically unlocked if the speed of the vehicle is greater than 11 km/hour and/or the engine speed greater than 2800 rpm.
	Slow flashing	If the warning light flashes slowly at slow speed this indicates that the system can be locked.	The speed of the vehicle must be less than 11 km/hour and the engine speed under 2800 rpm when the switch is set to the locking position.   Unlocking the front axle may lead to the vehicle falling over. If the vehicle is stopped with the rotating knob set to the "on" position, do not operate the throttle (engine running) or the anti-Tilting switch if the stability of the vehicle is not under control.
	Fast flashing	The system is faulty.	In this case, the engine speed is limited to 2000 km/h. You are advised to have the vehicle checked by an authorised dealer.   In case of malfunction of the anti-tilting system when locked or a battery fault, the hinge can be released manually. See chapter: <a href="#">Repair procedures</a> page 37 .
Ⓟ Electric parking brake warning light.	Off	The parking brake is released.	
	Fixed	If the warning light is lit, the parking brake is on.	When the parking brake is on, the engine speed is limited to 2000 rpm.
	Flashing	The system is faulty.	In this case, the engine speed is limited to 2000 rpm. You are advised to have the vehicle checked by an authorised dealer.   In case of malfunction of the parking brake when engaged or a battery fault, a manual release procedure is possible to allow the vehicle to be moved. See chapter: <a href="#">Repair procedures</a> page 37 .

Indicator	Status	Cause	Actions / Observations
 Traction control indicator light (Traction Control System)	Off	The system is functioning correctly but is inactive.	The system is automatically activated each time the vehicle starts up.
	Fast flashing	The system is functioning correctly and is active (Low grip conditions).	 When the grip level is reached, you should reduce your speed to ensure your safety on the road.
	Fixed	The system is deactivated and does not operate if grip is lost (Mode: Deactivated).	 To guarantee maximum grip, make sure the traction-control function is on (1 mode, 2 mode).
	Fixed	If the warning light is steadily lit with mode 1 or 2 selected, this means that the system is faulty.	You are advised to have the vehicle checked by an authorised dealer.
 Engine lubrication warning light <sup>1</sup>	Fixed	When the engine is running, the warning light is indicative of a failure of the engine lubrication system.	 It is imperative to stop the vehicle under the best possible conditions of safety and to turn off the engine. You are advised to have the vehicle checked by an authorised dealer.
 When the oil pressure warning light comes on while the engine is running, a warning message appears in the digital display at regular intervals.			
 Engine temperature warning light	Fixed	A high temperature reading is indicated by a red warning light.	 You are advised to switch off the engine and check the coolant level after it has cooled down. If the level is correct, have the vehicle checked by an approved dealer.

<sup>1</sup> Depending on equipment.

## DIGITAL DISPLAY

You can change the appearance of the handset by selecting:

- A display colour.
- A background colour.
- The display of certain information (See chapter: "[Personalisation - Configuration](#)" menu page 15 ).

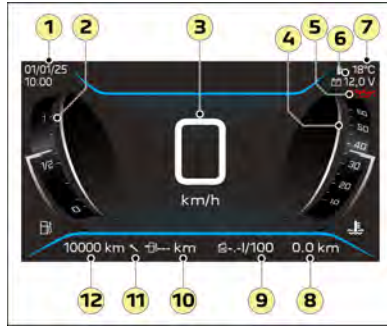

### 1. Date / Clock.

Setting the date and time (See chapter: "[Personalisation - Configuration](#)" menu page 15 ).

### 2. Fuel gauge.



**p**

When the reserve level is reached, the (p) warning light appears in orange, indicating a minimum fuel level. There are 3 litres of fuel remaining.



Fill the tank as soon as possible to prevent a breakdown.

### 3. Digital speedometer (km/h or mph).

### 4. Engine temperature gauge.



**t**

A high temperature reading is indicated by a red warning light (t).



You are advised to switch off the engine and check the coolant level after it has cooled down. If the level is correct, have the vehicle checked by an approved dealer.

### 5. Engine oil pressure warning light.

When the engine is running, the warning light is indicative of a failure of the engine lubrication system.



It is imperative to stop the vehicle under the best possible conditions of safety and to turn off the engine. You are advised to have the vehicle checked by an authorised dealer.

### 6. Battery voltage.

The battery voltage is displayed and the "battery" symbol.



If the battery charge symbol appears in red while driving, you are advised to have the battery charge system checked by an approved dealer.

### 7. Outside temperature gauge (°C or °F).

The temperature shown is that read on the front of the vehicle.



The "risk of black ice" symbol comes on as soon as the temperature falls below 3°C.

### 8. Tripmeter.

The tripmeter displays and stores the number of kilometers travelled during a given period. The vehicle's trip meter remains in the memory even when the battery is disconnected.

Resetting the tripmeter:

- Reset the tripmeter by pressing the "SELECT" and "EXIT" buttons simultaneously for 3 seconds (Or using the Personalisation - Configuration menu) (see relevant chapter).

## 9. Average consumption indicator.

- It indicates the average fuel consumption during the last 10 minutes of engine operation.
- It is updated every minute.



This figure may vary following a change in driving or in the relief, resulting in a significant variation in average consumption.

## 10. Autonomy indicator.

- The number of kilometres can be calculated from the remaining fuel in the tank (based on the average consumption over the last 10 minutes).
- It is updated every minute.

## 11. Maintenance indicator.

- Each time the ignition is switched on, the display indicates the milage remaining before the next service.
- When the kilometres to maintenance reaches zero, the maintenance symbol remains lit on the display.

Maintenance frequency (Default value)	10000 km
------------------------------------------	----------



This period does not include the first inspection at 1000 km and concerns normal servicing.  
See service book for harsh-use servicing.

Maintenance counter reset:

See chapter: "[Personalisation - Configuration](#)" menu page 15 .



You are advised to make an appointment for vehicle maintenance at an approved dealer.

## 12. Milometer.

- The tripmeter displays and stores the number of kilometres travelled by the vehicle. The machine total kilometres remains in the memory when the battery is disconnected.

## "PERSONALISATION - CONFIGURATION" MENU

This menu can be used to access the following settings:

- Instrument panel personalisation.
- Language selection.
- Setting the date and time.
- Daily counter reset.
- Measurement unit selection.
- Backlighting.

Turn on the ignition and hold the "EXIT" control for 2 seconds to open the menu.

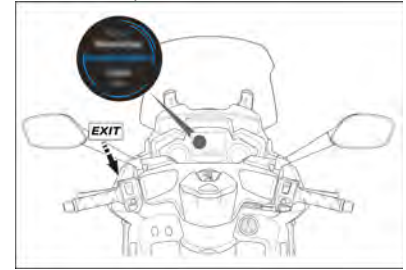

Manipulations are only possible when the vehicle is stopped.

The functions which can be accessed via the configuration menu are described in detail in the table below

GB

Menu	Button action	Sub-menu	Comments
EXIT > 2S ←→ SELECT > 2S + Validation			
TRIP	SELECT ↑ <1S ↓ EXIT	• Trip reset	Daily counter reset. Quick procedure: Reset the tripmeter by pressing the "SELECT" and "EXIT" buttons simultaneously for 3 seconds.
		• Activated • Deactivated	Daily counter display (or not).
• Colour		• Blue • Golden • Red	Choice of digital display colour.
• Background		• Black • White	Choice of screen background colour.
• External temp.		• Activated • Deactivated	Display or hide the temperature gauge.
• Avg. consumption		• Activated • Deactivated	Display or hide average consumption.
• Remaining range		• Activated • Deactivated	Display or hide autonomy.
• Battery voltage		• Activated • Deactivated	Display or hide the battery voltage.
Personalization			

Menu	Button action	Sub-menu	Comments	
EXIT > 2S ← → SELECT > 2S + Validation				
<b>Language</b>	SELECT ↑ <1S ↓ EXIT	<ul style="list-style-type: none"> <li>• Français</li> <li>• English</li> <li>• Deutsch</li> <li>• Español</li> <li>• Italiano</li> </ul>	Language selection.	
		<ul style="list-style-type: none"> <li>• Maintenance</li> </ul>	<ul style="list-style-type: none"> <li>• Reset</li> </ul>	Maintenance indicator reset.
		<ul style="list-style-type: none"> <li>• 2500</li> <li>• 3000</li> <li>• 5000</li> <li>• 10000</li> </ul>	Choice of maintenance interval (Consult the maintenance manual).	
<ul style="list-style-type: none"> <li>• TCS</li> </ul>			Choice of traction control mode.	
		<ul style="list-style-type: none"> <li>• Mode 1</li> </ul>	This mode is recommended for all types of usage, especially on wet roads (Default mode).	
		<ul style="list-style-type: none"> <li>• Mode 2</li> </ul>	This mode is less sensitive but is always on. More suitable for worn road surfaces, it provides an alternative to mode 1 if desired.	
		<ul style="list-style-type: none"> <li>• Deactivated</li> </ul>	 To guarantee maximum grip, make sure the traction-control function is on (1 mode, 2 mode).	
		<ul style="list-style-type: none"> <li>• Showroom mode</li> </ul>	The Showroom mode disappears when the vehicle has travelled more than 30 km.	
		<ul style="list-style-type: none"> <li>• Date</li> </ul>	<ul style="list-style-type: none"> <li>• Adjust with up/down</li> </ul>	Date setting.
		<ul style="list-style-type: none"> <li>• Time</li> </ul>	<ul style="list-style-type: none"> <li>• Adjust with up/down</li> </ul>	Time setting.

Menu	Button action	Sub-menu	Comments
EXIT > 2S ← → SELECT > 2S + Validation			
Preference	SELECT ↑ <1S ↓ EXIT	<ul style="list-style-type: none"> <li>Units</li> </ul>	<ul style="list-style-type: none"> <li>Metric</li> <li>Imperial</li> </ul> <p>Measurement unit selection: If the distance unit is kilometres, the outside temperature is displayed in °C. The autonomy indicator is in L/100 km. If the distance unit is miles, the outside temperature is displayed in °F. The autonomy indicator is in MPG.</p>
		<ul style="list-style-type: none"> <li>Hour format</li> </ul>	<ul style="list-style-type: none"> <li>24H</li> <li>AM/PM</li> <li>Deactivated</li> </ul> <p>Choice of time format. Display or hide the time.</p>
		<ul style="list-style-type: none"> <li>Date format</li> </ul>	<ul style="list-style-type: none"> <li>ddmmyy</li> <li>yymmdd</li> <li>Deactivated</li> </ul> <p>Choice of date format. Display or hide the date.</p>
Backlighting		<ul style="list-style-type: none"> <li>BL0</li> <li>BL1</li> <li>BL2</li> <li>Automatic</li> </ul>	<p>Digital display brightness setting: Low (BL0), Average (BL1), High (BL2), or Automatic. (BL = Backlighting).</p>

## CONNECTIVITY MENU (DEPENDING ON MODEL) (I-CONNECT)

- ✓ Download the Peugeot Motorcycles app from the store corresponding to your smartphone.

This menu accesses the following functions:

- Bluetooth®.
- Call.
- Message.
- NAVIGATION.

Turn on the ignition and hold the "SELECT" control for 2 seconds to open the menu.

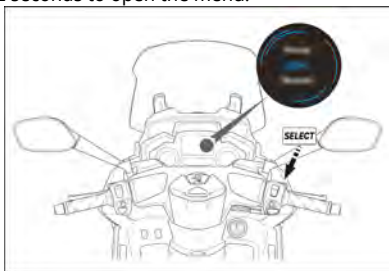

- ✓ Manipulations are only possible when the vehicle is stopped.

The functions which can be accessed via the connectivity menu are set out in the table below.

Menu		Comments
Bluetooth®	🔌	Bluetooth function activation/deactivation.
Call	📞	Incoming calls display activation/deactivation.
Navigation		Navigation mode activation/deactivation.
Message	✉️	Message display activation/deactivation.

## Pair a Bluetooth® telephone (Depending on model)



For safety reasons and because the driver's full attention is required, using a smartphone while driving is prohibited.



Enable mobile Internet data on your smartphone (or wifi).  
If another smartphone is already connected to the vehicle, pairing with a second smartphone will be rejected. Check that there are no other connected smartphones nearby: disable its Bluetooth connection.

1. Download the PEUGEOT MOTOCYCLES app from the store corresponding to your smartphone.
2. Create an account.
3. From the "connectivity" menu, enable the vehicle's Bluetooth function.
4. Activate the Bluetooth function on your smartphone.
5. Open the PEUGEOT MOTOCYCLES application on your phone.
6. From the Settings tab, press "Scooters" and then "ADD A NEW SCOOTER".
7. Using your telephone key pad, enter the same PIN code displayed on the screen and confirm.



If this fails, you are advised to deactivate then reactivate the Bluetooth function on your phone.

For further information about how to use the app. See chapter: [Mobile app](#) page 20 .

## Digital display (Depending on model)

Overview of the digital display with the GPS function activated.



1. Notification of an incoming call or message.
2. Display of the number or name of an incoming call or the number or name plus the start of the message.
3. Remaining distance.
4. Estimated arrival time.
5. Engine speed limitation.
6. Distance to the next direction.
7. Name of the current road.
8. Name of the road on the next direction.
9. Direction to take.



Activation of mobile internet data is obligatory for connected navigation.

GB

### MOBILE APP

✓ Telephones (models, operating system versions) each have their own specific features which may affect the pairing process. Some telephones may not be compatible.

⚠ For safety reasons and because the driver's full attention is required, using a smartphone while driving is prohibited.

✓ Enable mobile Internet data on your smartphone (or wifi). If another smartphone is already connected to the vehicle, pairing with a second smartphone will be rejected.

✓ To benefit from all the functions, ensure you are in an area covered by the mobile network.

Download the PEUGEOT MOTOCYCLES app from the store corresponding to your smartphone.

Minimum configuration to be able to download the app:

- iOS 10.0
- Android 5.0

The app is available in 5 languages: French / English / Deutsch / Italian / Español.



The native language of the telephone is used when the app is installed. If the native language of the telephone is not available in one of the languages of the app, it automatically sets itself in English.

### CREATING THE ACCOUNT



All the fields must be completed to finalise creation of the account (Otherwise the app returns an error). The minimum length of the password is 8 characters.

✓ To create an account, enable mobile Internet data on your telephone (or wifi). 5 accounts can be registered in the connectivity box. Any new account replaces the oldest one. The number of smartphones connected to the account is not limited.

### Forgotten password



To recover their password, the user must first enter their email address and then click on the link, otherwise the app will return an error.

## PAIR A BLUETOOTH® TELEPHONE

✓ Telephones (models, operating system versions) each have their own specific features which may affect the pairing process.  
Some telephones may not be compatible.

✓ If another smartphone is already connected to the vehicle, pairing with a second smartphone will be rejected.  
Check that there are no other connected smartphones nearby: disable its Bluetooth connection.

1. Press 5 times on the rotating knob to cancel automatic ignition cut-off (At the end of the procedure, switch off the ignition to avoid discharging the battery).
2. From the "connectivity" menu, enable the vehicle's Bluetooth® function.
3. Activate the Bluetooth function on your smartphone.

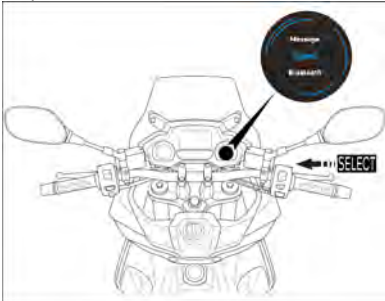

4. Open the PEUGEOT MOTOCYCLES application on your phone.

5. From the Settings tab, press "Scooters" and then "ADD A NEW SCOOTER".



✓ When the app is launched for the first time, there is a shortcut to get to this page in the homepage under the photo of the vehicle.

6. Using your telephone key pad, enter the same PIN code displayed on the screen and confirm.

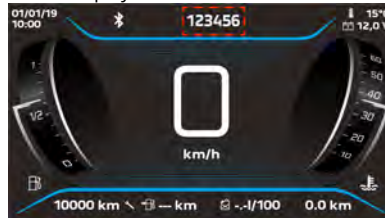

✓ Depending on the telephone model or version, you may need to accept the pairing in the notifications.



If download fails, check (impossible to enter the pairing code, etc.):

- Shut down the PEUGEOT MOTOCYCLES app completely (check it is not running in the background).
- Check that there are no other connected smartphones nearby: disable its Bluetooth connection.
- Activate Bluetooth and restart the PEUGEOT MOTOCYCLES app on the smartphone to be paired.

GB

## HOMEPAGE

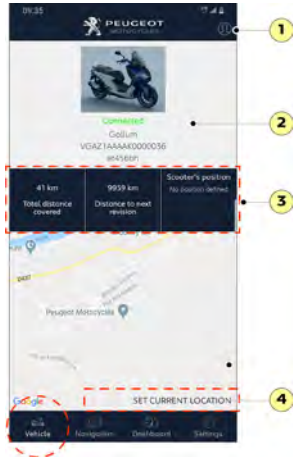

1. Profile access
2. Vehicle information reminder
3. Tripmeter / Maintenance / Position of the vehicle.
4. Button to save vehicle position.

## Profile

All the fields except for the "Email" field can be modified.

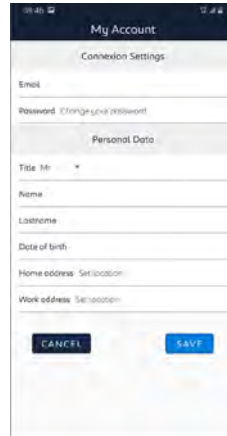

The home address and work address information is duplicated in the navigation tab.

## "NAVIGATION" PAGE

- Map supplier: HERE MAPS
- Navigation strategy: Offline (to avoid losing the signal).

Before any navigation searches, you must download the map of the region.

You are advised to download it on a WiFi network (From 250 MB to 1 GB. Depending on the region or country).



Check the storage space available on your telephone.

1. Search bar / History of the last 5 navigation searches.
2. Home and work address shortcuts saved in the profile.
3. Information about the traffic state in real time to know if navigation will be complicated or not.
4. Compass to reposition the map to the north.
5. Recentering the map on your position.



## Preview of the trip

- When choosing to start navigation, the app checks if the vehicle has sufficient autonomy to complete this trip. If it does not, an information window opens.

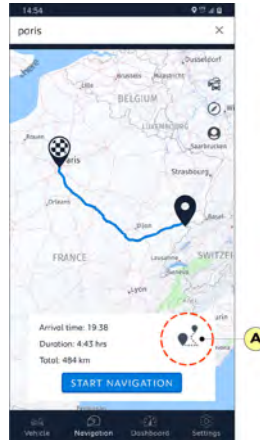

By pressing on the icon (A) you can change or adapt the navigation options as needed.



GB

## "DASHBOARD" PAGE

### 1. LIVE tab.

Information in real time concerning:

- Vehicle speed.
- The engine speed.
- The outdoor temperature.
- The battery voltage.

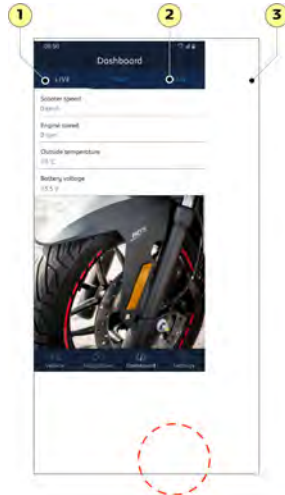

### 2. TRIP tab.

Information concerning:

- The journey distance.
- The tripmeter.
- The fuel level.
- The autonomy.
- The average consumption.



### 3. DIAG tab.

Non-functional tab / Under development.



## "SETTINGS" PAGE

1. Scooters.
  - List of scooters linked to the account.
2. Scooter configuration
  - Instrument panel configuration (Language selection. Choice of digital display colour, . . .).
3. Maps
  - Installed map.



### 1. List of scooters linked to the account.

- Possibility to manage the vehicle in the list as you wish. Either by deleting it, selecting it or editing it.
- In the Edit part, you can change the name of the vehicle and replace the image with another from the gallery (A).



- When adding a new vehicle to the app, you have to go through the app and enter the pairing code indicated by the instrument panel.



When the app is launched for the first time, there is a shortcut to get to this page in the homepage under the photo of the vehicle.

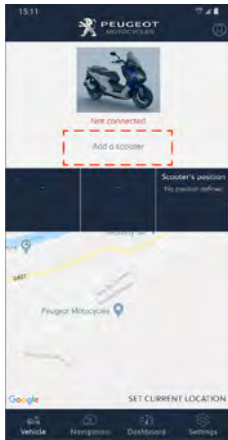

## 2. Instrument panel configuration

- Changing the parameters from the app is performed in real time on the instrument panel (When the connection is active).



Refresh the app page when the changes have been made from the instrument panel.

## 3. Mapping

Possibility to install or uninstall the desired region to navigate in the region of your choice.



Check the storage space available on your telephone.



Using the Internet involves data transfer which is invoiced. Contact your mobile telephone operator to know the data transfer costs.

## SMART KEY KEY, ROTATING KNOB AND OPENINGS

### smart key key

According to the version, your vehicle is delivered with:

- Two smart key, each including an integrated emergency key.
- A label with the key code (A label is to be affixed in the maintenance manual in the place provided for this purpose).

✓ The code is essential for key programming.

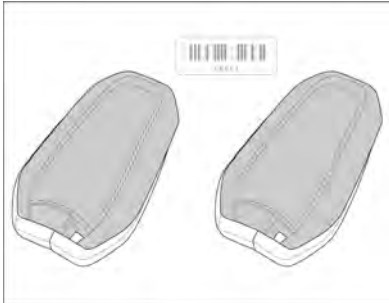

The smart key key is an electronic key which is recognised by the system within a radius of 1.5 meters and:

- Switches on the engine.
- Unlocks the storage compartments.



Do not store the smart key in a place where it could become damaged or be accidentally broken: For example, storing the smart key in the rear pocket of clothing.



To avoid any risk of accident of theft, never leave the smart key key near the vehicle or in one of the storage compartments.



The smart key may not function if it is near an electronic appliance: telephone, laptop, intense magnetic fieldsetc.

### Emergency key.

An emergency key is integrated into the smart key key.

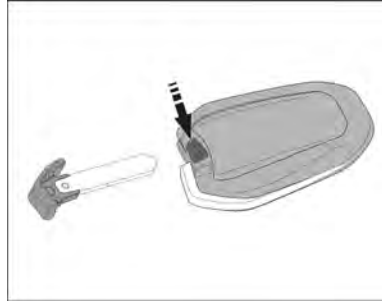

The emergency key is only used in exceptional cases to unlock the rear storage compartment if the vehicle battery is flat.

See chapter: [Repair procedures](#) page 37 .

### Rotating knob



If the smart key key is not recognised, the rotating knob cannot be turned. It is only possible to press the knob. In this case the lighted surround flashes quickly for 5 seconds.

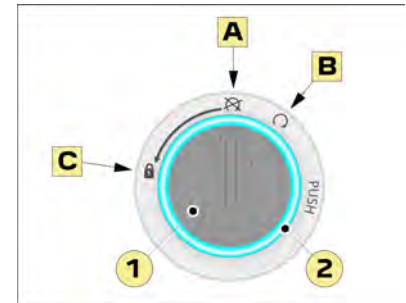

1. Rotating knob.
2. Lighted surround (Blue).

#### A. Stop position.

Power to the electrical circuit is off. Press and hold the rotating knob for one second to wake up the system; the lighted surround lights up to indicate the presence of the smart key: The knob is unlocked. Turn the rotating knob to the "ON" (B) position within a maximum of 5 seconds.

#### B. On/start position.

Power to the electrical circuit is on. The engine can be started.



With the ignition on, the circuit is automatically cut off after 30 seconds if the engine is not started.

GB

**C. Steering unlocked.**

The steering is locked and all of the electrical circuits are shut off.

- Lock the steering.
  - Turn the handlebar to the left.
  - Press the rotating knob for one second to wake up the system: the light around the edges lights up.
  - Turn the rotating knob to the lock position.
- Unlock the steering.
  - Press the rotating knob for one second to wake up the system: the light around the edges lights up.
  - Turn the rotating knob to position (A).

## No smart key recognition

If the smart key is not recognised, the vehicle can be started using the following procedure.

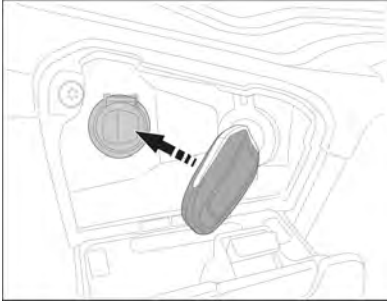

- Open the glove box.
- Hold the smart key against the emergency antenna.
- Press and hold the rotating knob for 2 seconds.
- Turn the rotating knob to ON.
- The vehicle should start.

Possible causes of non-recognition:

- Low battery or incorrectly positioned.
- Radio disturbance.
- Damaged smart key.

## Changing the battery

If the battery is worn out, the lighted surround on the rotating knob flashes slowly when the ignition is switched on.



You are advised to change the battery every 2 years.

Battery: CR2032 / 3 Volt.

- Unclip the smart key cover.
- Carefully remove the spent battery.

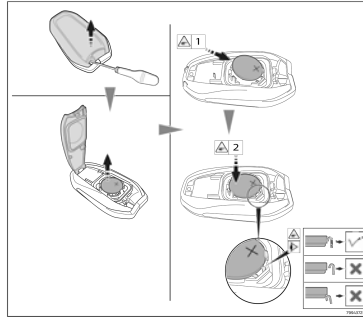

- Carefully fit the new battery, ensuring it is the right way round and following the installation instructions.
- Clip the cover on.

## Replacing or adding a smart key

If you lose or would like an additional smart key, go to your approved dealer with the vehicle registration certificate, your ID card and label with the key codes.



Up to 4 smart key keys can be registered in the system.

## OPENINGS

### Glove box

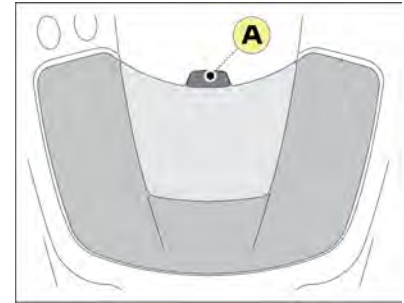

Open the glove compartment by pressing button (A).

### Storage compartments

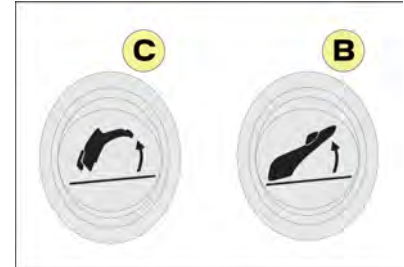

With the smart key present, press on a control button to unlock the corresponding storage compartment.

- B.** Unlocking control for front storage compartment.
- C.** Unlocking control for rear storage compartment.



When the ignition is switched off, if a button remains in the pressed position, the lighted surround of the rotating knob flashes quickly for 30 seconds.

GB

✓ When the vehicle is moving, the storage compartment opening buttons are not active.

✓ You are advised not to leave any objects in the storage compartments, whatever the value (helmet, document-holder, etc.), the manufacturer may not be held liable in the event of theft or intrusion.

## EQUIPMENTS

### Adjustable windshield

This vehicle is fitted with a height-adjustable windshield.

Procedure:

- Press simultaneously on the buttons and move the windshield up or down according to the desired position.

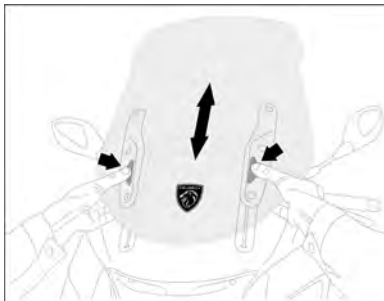

Release the buttons and gently move the windshield to lock it into the notches.

### Utility hanger

Located in front of the saddle this is used to hang a bag weighing not more than 10 kg.

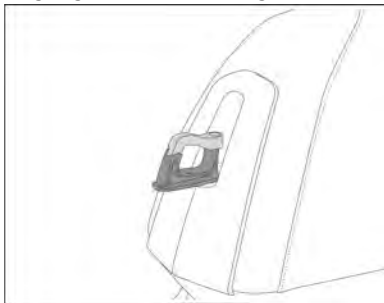

### Storage compartment / (USB) accessory socket

A USB socket fitted in the storage compartment, powered when the ignition is switched on, allows you to connect a mobile device (MP3 player, telephone, GPS, etc).

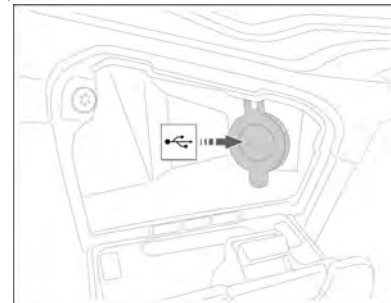

The equipment can recharge automatically during use.

### Adjusting the handlebar (Version GT)

- Slightly loosen the handlebar screws.
- Tilt the handlebar forwards or backwards according to your preference.

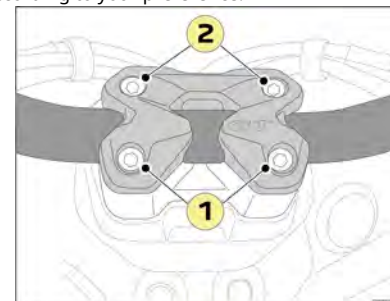

- First tighten the rear screws (1) and then the front screws (2) (Tightening torque: 25 Nm).

- C. Centring marks on the handlebar.
- D. Marks for standard position / Adjustment limit.

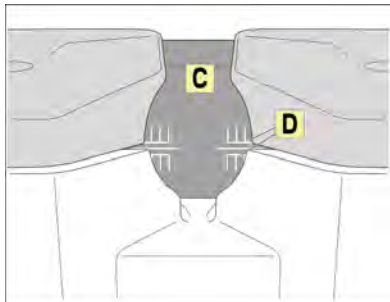

After adjustment, check that the wing mirrors do not come into contact with the windshield when turning the handlebar. Modify their positions if necessary.

## Rear storage compartment

### Opening the storage compartment flap

- With the smart key present, press the control button to unlock the rear storage compartment.
- Lift the storage compartment flap up to the upper stop. It will remain in position<sup>2</sup>.



Do not put any strain on the cover beyond its fully open position. When in open position, do not place any load inside or on top of the cover.

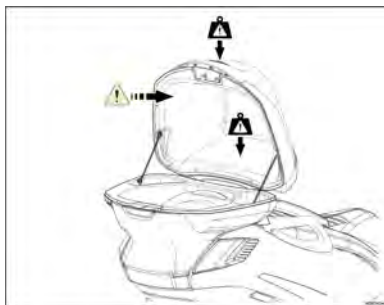

### Closing the storage compartment flap

- Lower the storage compartment flap half way and allow it to lower under its own weight to lock it.



Risk of injury: Do not put your hands between the flap and the storage compartment while it is closing.

## Storage compartment space Metropolis SW

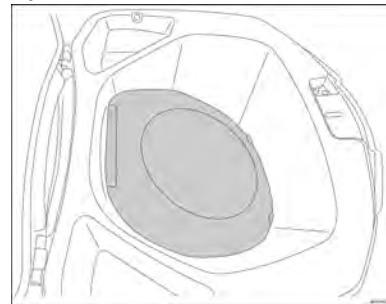

- A partition separates the space in the rear storage compartment.
- It can be used, for example, to separate 2 helmets.

### Storage compartment lighting

The storage compartment light comes on automatically when it is opened and switches off automatically when it is closed. If a storage compartment is left open, the lighting automatically switches off after 4 minutes.

### Adjustable driver's backrest

The saddle can be adapted to suit the driver's position.

<sup>2</sup> Depending on model.

**Procedure for adjusting the backrest**

- Open the front storage compartment.
- Use the male offset wrench (A) to unscrew the 2 screws (B).

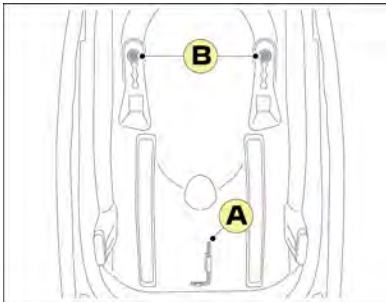

- Move the backrest forwards or backwards to the desired position.

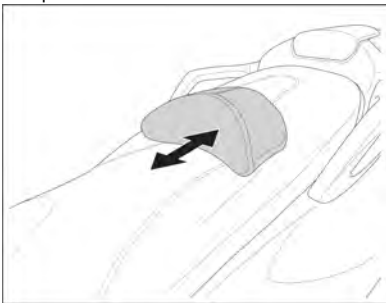

- Tighten the 2 screws.
- Fit the male wrench back into its housing.
- Close the storage compartment.

**Adjustment of damper settings**

Each damper has an adjuster ring that can be used to stiffen or soften the suspension, depending on the vehicle load.

**Metropolis Active and Allure**

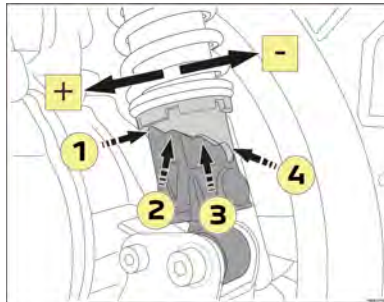

- Place the vehicle on the central stand.
- Turn the adjustment ring to change the damper preload.

Adjusting the suspension	
Notch 1	< 80 kg
Notch 2	80 to 100 kg
Notch 3	100 to 120 kg
Notch 4	> 120 kg



To guarantee your comfort and safety, always adjust the damper preload in line with the vehicle load.



Perform the same setting for the 2 dampers.

**Metropolis GT and SW**

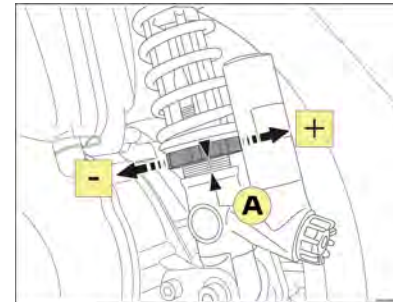

- Place the vehicle on the central stand.
- Turn the adjustment ring to change the damper preload.
- Measure the distance between the adjustment ring and the body of shock absorber (A).

Adjusting the suspension	
A = 8 mm	< 80 kg
A = 13 mm	80 to 100 kg
A = 27 mm	100 to 120 kg
A = 28 mm	> 120 kg



To guarantee your comfort and safety, always adjust the damper preload in line with the vehicle load.



Perform the same setting for the 2 dampers.

**Damping force adjustment**

This setting affects the compression and rebound of the shock absorbers. Turn the adjustment wheel to increase or decrease the damping force.

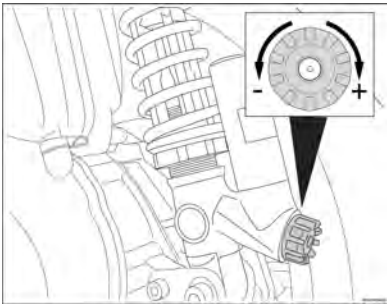

**Standard position:**

Turn the adjustment wheel clockwise to set it to the hardest position, then loosen it by 9 notches.



Perform the same setting for the 2 dampers.

## CHECKS TO PERFORM BEFORE USE

The user must personally ensure that his vehicle is in good condition. Certain safety elements may show signs of damage even when the vehicle is not used. e.g. prolonged exposure to bad weather can lead to oxidation in the braking system or a pressure drop in the tyres which can have serious consequences. In addition to a simple visual inspection, it is extremely important to check the following points before use.



These checks only take a few minutes and help to keep your vehicle in good condition, for optimum use combining reliability and safety.

If one of the elements in the checklist does not work properly, ask your registered dealer to check it and have it repaired if necessary before using the vehicle.

## ADVICE FOR STARTING UP AND DRIVING

### Warning

Before using the vehicle for the first time, make sure you are familiar with all the controls and their respective uses. If you are not sure about the functions of any of the controls, your registered dealer can answer your questions and give you any help you may require.



As exhaust fumes are toxic, the engine must be started in a well-ventilated area. It must never be allowed to run in a closed space, even for a short time.

### Eco mode

#### Adopt smooth driving behaviour

- Turn the acceleration handle gradually, not suddenly.
- Anticipate braking using the engine brake.
- Limit the vehicle load as well as aerodynamic resistance.
- Regularly check the inflation pressure in your tyres, and refer to the label under the seat.
- Avoid heating up the engine while stationary: the engine heats quicker when you drive.
- Have your vehicle serviced according to the manufacturer's maintenance plan.

**These attitudes contribute to economising fuel consumption, reducing CO2 emissions and alleviating the background sound of traffic.**

## Driving on flooded roads



You are strongly advised not to drive on flooded roads as this may seriously damage the engine, transmission and electrical systems on your vehicle.

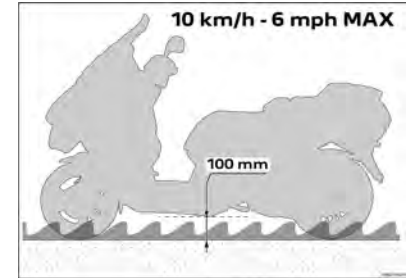

If you cannot avoid driving through flood water:



- Check that the water depth does not exceed 100 mm, taking into account waves which could be generated by other road users.
- Under no circumstances exceed a speed of 10 km/h.
- Once out of the flooded area, brake gently several times to dry out the brakes as soon as the safety conditions allow it.

## Inspection before setting off

Component	Checks
Fuel	<ul style="list-style-type: none"> <li>• Check the fuel level in the tank.</li> <li>• Top up with fuel if necessary.</li> <li>• Check that there is no fuel leak.</li> </ul>
Engine oil	<ul style="list-style-type: none"> <li>• Check the level of the engine oil.</li> <li>• If necessary, top up with the recommended oil.</li> </ul>
Coolant	<ul style="list-style-type: none"> <li>• Check the coolant level in the header tank.</li> </ul>
Disk brakes	<ul style="list-style-type: none"> <li>• Check brake operation.</li> <li>• Have an approved dealer check them if they feel soft.</li> <li>• Check brake pad wear.</li> <li>• Check the level of brake fluid in the reservoir.</li> </ul>
Lighting, signalling, indicators, horn	<ul style="list-style-type: none"> <li>• Check operation.</li> <li>• Correct if necessary.</li> </ul>
Wheels and tyres	<ul style="list-style-type: none"> <li>• Check the tyre wear and condition.</li> <li>• Check the tyre pressures cold.</li> <li>• Correct if necessary.</li> </ul>
Throttle	<ul style="list-style-type: none"> <li>• Check the throttle handle turns smoothly and returns correctly to its starting position.</li> </ul>
Steering	<ul style="list-style-type: none"> <li>• Check the free rotation of the steering.</li> </ul>
Stand	<ul style="list-style-type: none"> <li>• Check that the central stand can be unfolded smoothly.</li> </ul>

## Starting the engine

For greater safety, place the vehicle on its central stand before starting the engine.

- The driver must carry the smart key key on his/her person.
- Turn the rotating knob to "ON". The lighted surround lights up steadily.
- Ensure that the emergency stop button is in the  position.
- Wait for the end of the instrument panel self-test.
- Ensure that the throttle is in the OFF position.
- Press one of the brake levers while pressing the starter button . Do not press the starter for more than 10 seconds.
- Release the starter button as soon as the engine starts.



In certain conditions, the smart key may not function if the vehicle is located in an area subjected to high electromagnetic radiation.



To avoid any accident, do not leave the vehicle unattended while the engine is running.  
For your safety and that of the vehicle, ride onto or off pavements facing straight at the kerb and at very low speed, with the handlebars and wheels straight. Preferably get off the vehicle to do so.

## Driving

### Starting off

The vehicle is on its stand with the engine running.

- Hold the handlebar with the left hand and the grab handle with the right hand and push the vehicle forwards to fold the central stand.
- Sit on the vehicle.
- Release the electric parking brake if necessary.
- To start the vehicle, gradually twist the throttle with your right hand.

## Accelerating and decelerating

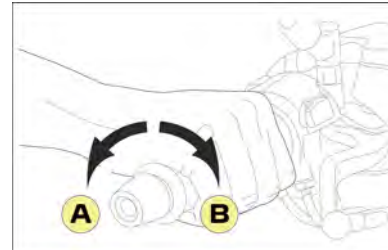

To accelerate, turn the throttle towards (A). To slow down, turn the throttle towards (B).

## Braking

### ABS Braking system

The ABS braking system is linked to an integrated braking system operated by the brake pedal.

- The ABS system enables the rider to retain control of the vehicle when braking in slippery conditions.
- The right and left brake levers operate in the same way as a conventional braking system, while retaining the ABS function.
- The right lever acts on the front wheels.
- The left lever acts on the rear wheel.

### Use of the brakes

- Close the throttle.
- Activate the brake system by gradually increasing the pressure.



Avoid braking suddenly on wet roads or in bends.

Reduce speed on steep slopes to avoid prolonged braking, as overheating will reduce braking efficiency.

## Fuel supply



The engine must be switched off in order to fill the fuel tank in complete safety.

GB

A label affixed near the fuel cap reminds you of the type of fuel to use.



- Open the front storage compartment.
- Remove the tank cap.
- Fill the tank, ensuring the nozzle is correctly inserted into the filling orifice.

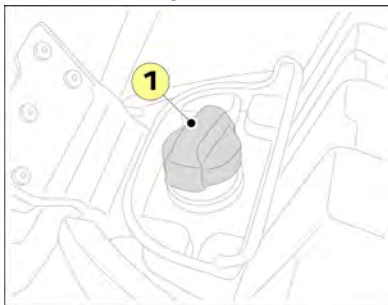

Any overflows must be wiped up immediately.

The fuel could actually damage painted surfaces or plastic parts.

Do not fill the fuel tank to excess: The fuel may expand due to the engine heat or heat from the sun and overflow.

## Running in the engine

Running in the engine is essential to guarantee its performance and lifetime.

During the running-in period, you are advised not to overload the engine and to avoid exceeding a higher than normal operating temperature.

### From 0 to 500 km

Do not hold the throttle handle open at more than half its distance of travel over a long trip.

### From 500 to 1000 km

Do not hold the throttle handle open at more than 3/4 its distance of travel over a long trip.

Once this mileage has been done, the vehicle can be used normally.

## Stopping the vehicle and parking

Stop the vehicle and switch of the engine by turning the rotating knob to "OFF".

The vehicle should be preferably parked on flat ground.

- On the central stand or on its wheels with the anti-tilting system activated.



Always engage the electric parking brake and lock the steering each time the vehicle is parked.

If the vehicle is parked on a steep slope, you are advised to engage the electric parking brake, lock the steering and lock the wheels against the edge of the pavement as shown in the diagram below.

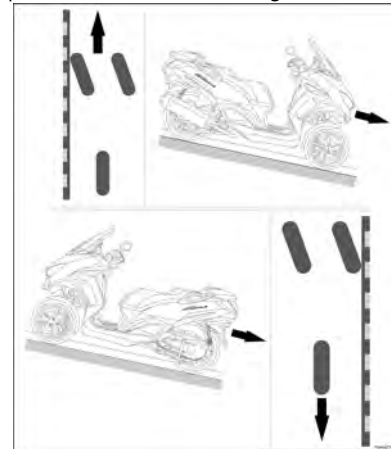



The parking brake and the Anti-Tilting might not hold the vehicle upright in all situations: Load on the vehicle, steep slope, prolonged immobilisation etc.

Preferably park the vehicle on the central stand.



You are advised not to leave any objects in the storage compartments, whatever the value (helmet, document-holder, etc.), the manufacturer may not be held liable in the event of theft or intrusion.

## REPAIR PROCEDURES

### Procedure for opening storage compartments

**If the battery is flat, the storage compartment can be opened as follows:**

- Remove the plastic cover at the back right side of the vehicle and unlock the rear storage compartment using the emergency key.

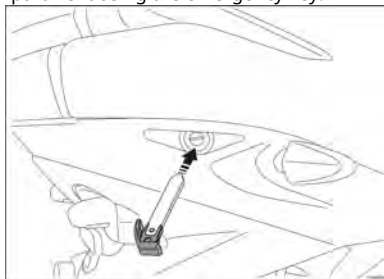

- Remove the cover (A).
- Unlock the front storage compartment by moving the lock to the left (B).

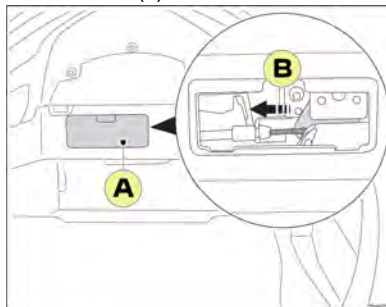

- Open the front storage compartment.
- Remove the battery cover.
- Remove the battery.

See chapter: [Battery](#) page 43 .

### Procedure for manual unlocking of the anti-tilting system

In case of malfunction of the anti-tilting system in the locked position or a battery fault, use the flat wrench in the front storage compartment to unlock the system manually.

The mechanism of the anti-tilting system is located at the front of the vehicle, behind the right wheel.



The vehicle must be placed on its stand.

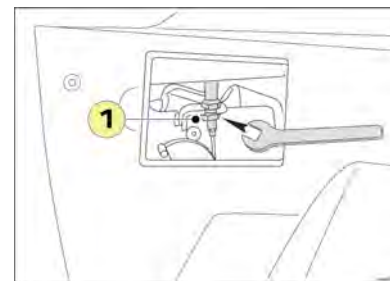

- Remove the plastic cover.
- Using the flat wrench, unscrew the nut (1).
- Remove the control from its holder.



If the system detects a fault, the engine speed is limited to 2000 rpm.

You must go to an approved dealer to have the system checked.

GB

## Procedure for manual unlocking of the parking brake

In case of malfunction of the electric parking brake in the engaged position or a battery fault, use the flat wrench in the storage compartment to unlock the mechanism manually and release the wheel so it can rotate.

GB

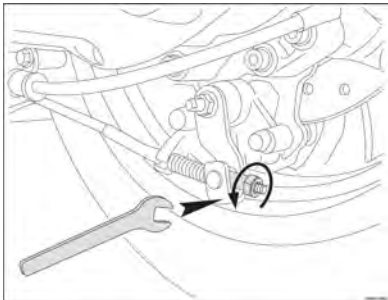

The parking brake mechanism is located at the rear wheel of the vehicle.



The vehicle must be placed on its stand.

- Unscrew the locknut.
- Turn the parking brake adjustment nut sufficiently to be able to loosen the control and free rotation of the wheel.



If the system detects a fault, the engine speed is limited to 2000 rpm.

This speed limitation can be removed by pressing and holding the parking brake button for 5 seconds.

You must go to an approved dealer as soon as possible at slow speed to have the system checked.

## SERVICE OPERATIONS

### Maintenance advice

**Ensure that the servicing schedule for your vehicle is strictly followed to maintain your contractual warranty rights.**

A table of inspections for the maintenance schedule is inserted into the maintenance booklet. The registered dealer must add his stamp, the date of servicing and the number of kilometres the vehicle has covered.

**In order to maintain maximum safety and reliability of your vehicle, you are advised to have maintenance and repairs carried out by a registered dealer who has the necessary technical training, specific tools and spare parts.**

### Environment / Recyclable

Worn parts replaced during routine maintenance (mechanical parts, battery, etc.) must be disposed of with specialised bodies.

At the end of its life, the vehicle must be taken to an authorised centre for recycling.

In all cases, comply with the local laws.



Batteries contain harmful substances. They must be disposed of according to the legal requirements and must under no circumstances be thrown away in the household waste.

### Cleaning the vehicle



The bodywork is made of plastic parts that can be painted or are shiny. Do not use solvents or cleaning products that are too corrosive.



Do not use high pressure cleaners which may cause water to infiltrate the following parts: seals, bearings and hinges, electrical components such as connectors, contactors and lighting.

Wash the bodywork with soapy water and rinse with generous amounts of clear water.

The vehicle can be dried with a chamois leather. After washing the vehicle, brake several times at low speed to dry out the brakes.



The vehicle should be washed in a place equipped for wastewater collection.

Certain silicon-based products can alter the quality of the paintwork. In case of need or doubt, a registered dealer can advise you on using cleaning products or restoring scratched bodywork.

### Spark plug inspection or replacement



It is essential to use a resistive spark suppressor and a resistive spark plug in accordance with the manufacturer's recommendations. We advise you to visit a registered dealer for the replacement of these components.

- The engine must be cold.
- Remove the saddle.
- Remove the fairing under the saddle.
- Disconnect the suppressor.
- Remove the spark plug.
- Measure the distance between the electrodes and correct it if necessary (A).

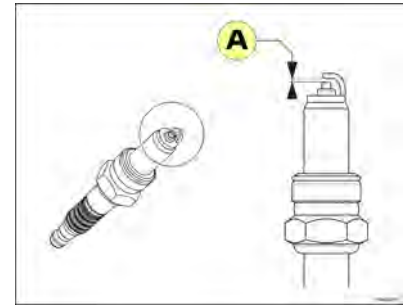

**A.** Electrode gap: 0.8 to 0.9 mm.

Spark plug	NGK CPR8E-9
------------	-------------

- Fit and screw in the spark plug manually.
- Tighten the spark plug with a spanner.
- 1/8 - 1/4 turn for a reused spark plug.
- 1/2 turn for a new spark plug.



Ensure the suppressor is correctly clipped onto the spark plug. Have the torque quickly checked by a registered dealer.

## Engine oil level



Check the oil level every 1000km / 600Mi or before a long journey.  
Any supplementary oil used must be oil recommended by the manufacturer.  
Too much oil will noticeably restrict the vehicle's performance.

### Level check

- To correctly measure the oil level, place the vehicle on the centre stand on flat ground.
- Start the engine, let it run for a few minutes and then stop it.
- After switching off the engine, wait for 5 minutes to allow the engine oil time to return to the oil sump.
- Remove the cap/oil gauge (1).

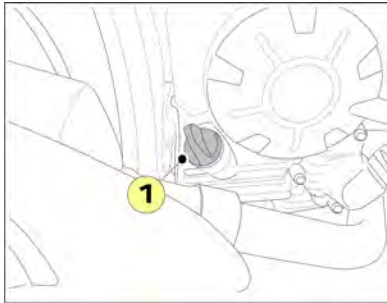

- Wipe the filler cap/gauge using a clean cloth and reinsert it into the filler hole without screwing it up.
- Remove the filler cap/gauge and check the oil level.
- The oil level shall be between the minimum (A) and maximum (B) level marks without exceeding the latter.

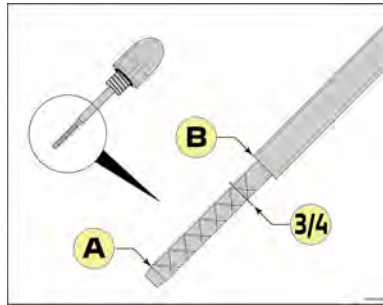

- If the oil level is close to the minimum mark or lower, you are advised to immediately top up the level to 3/4 in small amounts using the oil recommended by the manufacturer.



Too much oil will noticeably restrict the vehicle's performance.

### Changing the engine oil



We advise you to go to a registered dealer for draining.



Oil contains substances which are harmful to the environment. Your dealer is equipped to dispose of used oil without endangering the environment and in compliance with current standards.

**The engine must be drained when it is warm to allow the oil to run easier.**

- Park the vehicle on its stand.
- Put on protective gloves.
- Remove the cap/oil gauge.
- Remove the drainage cap and its seal (2) and allow the oil to drip into a recipient.

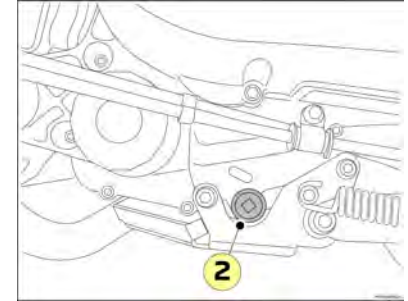

- Insert the drain plug fitted with a new seal (Tightening torque: 38 Nm).
- Pour the required quantity of oil corresponding to the manufacturer's standards into the filler hole.
- Fit the cap/oil gauge.
- Start the engine and let it run for a short while.
- Check and adjust the oil level if necessary.
- Check that the oil drain plug is sealed.

**SAE 5W40  
100% synthetic  
Minimum API SN quality**

#### Quantity:

• Without oil filter replacement	1.8 l
• With oil filter replacement	2 l

## Replacing the oil filter



We advise you to go to a registered dealer for draining.



Oil contains substances which are harmful to the environment. Your dealer is equipped to dispose of used oil without endangering the environment and in compliance with current standards.

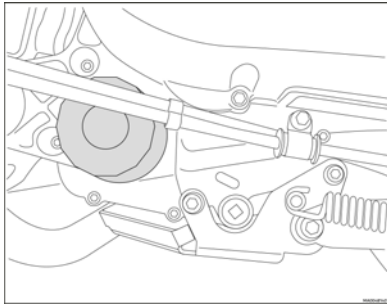

- Remove the oil filter cartridge using an oil filter wrench.
- Lubricate the rubber seal of a new oil filter.
- Fit a new cartridge tightened by hand and lock it with a 1/4 turn.
- If you use a socket type oil filter wrench with square fitting for use with a torque wrench, tighten the filter to 14 Nm.
- Check and adjust the oil level if necessary.

## Coolant level check

The filler cap/gauge is located in the rear shield panel after removing the hatch.

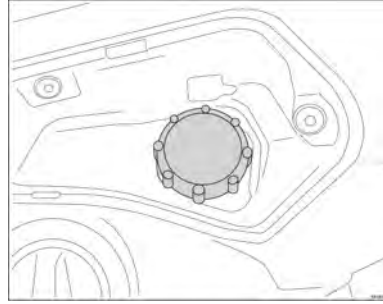

The coolant level must be cold checked regularly and topped up only with coolant recommended by the manufacturer.

- Park the vehicle on its stand.
- Remove the header tank cap.
- Check the coolant level and if necessary top up in the header tank until level MAX is reached.

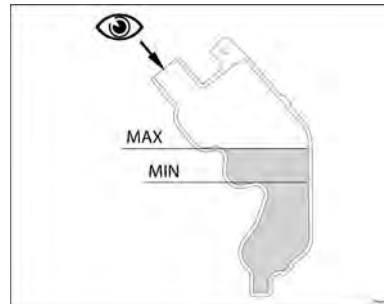

<b>Coolant</b>	MOTUL. Type C
	Anti-corrosion and anti-freeze Protection -37°C/-35°F Nitrite free / Amine free / Phosphate free

## Air filter element

- Park the vehicle on its stand.
- Remove the air filter cover.

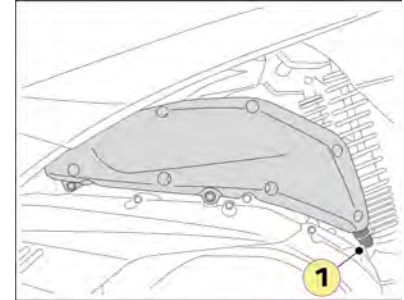

- Remove the air filter.
- Clean inside the air filter box.
- Check the condition and correct position of the 2 seals.
- Fit a new air filter.
- Re-fit the cover.
- Remove the inlet silencer drain plug to let humidity and oil drip out (1).

GB

### Throttle cable play

The play in the throttle control must be 3 to 5 mm on the handle (A).

If the play is incorrect, use the setting nut to adjust it (1).

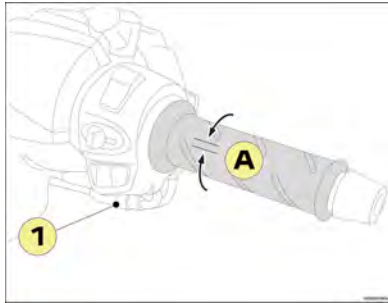

### Tyres

#### Tyre pressure



The tyre pressure must be checked once a month when cold. Incorrect pressure causes abnormal wear and affects road behaviour, thus making driving dangerous.

Tyre pressures		
	Front	Rear
Solo/Pillion	2 bars	2.5 bars

### Tyre wear

If the wear limit on the tread is reached (A), you are advised to go to a registered dealer to change the tyres.

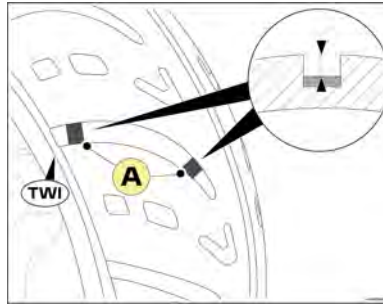

When replacing tyres, you are advised to mount tyres of the same brand and equivalent quality. In case of puncture, it is forbidden to mount an inner tube in a tubeless tyre. When removing the front wheels, mark their mounting position on the vehicle.



Tyres contain substances that are harmful to the environment. Your dealer is equipped to dispose of used tyres without endangering the environment in compliance with current standards.

### Brake inspection



We advise you to visit a registered dealer for the replacement of these components.

### Front brake pad wear

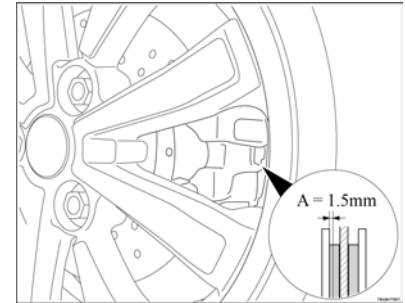

### Rear brake pad wear

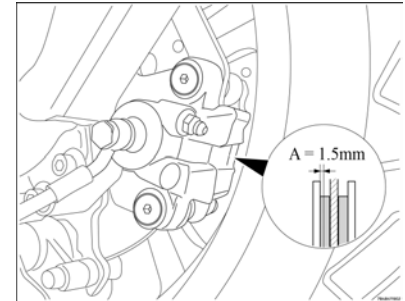

If one of the 2 brake pads is worn down to the minimum dimensions (A), the 2 brake pads must be changed.

## Brake fluid



The brake fluid levels must be checked regularly through the braking unit inspection window (B).



If the level is near the minimum mark, it is advisable to take the vehicle to an approved dealer as soon as possible to check the brake system and refill it if necessary.

Before verifying the liquid level, ensure that the reservoir of the brake master cylinder is horizontal.

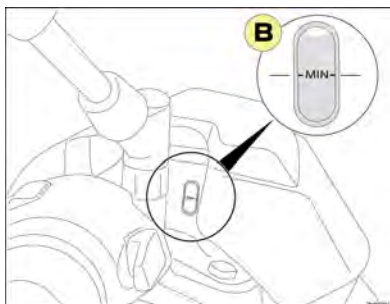

## ABS braking system



Regularly check the brake fluid level in the reservoir located under the front bodywork C.



If the level is near the minimum mark, it is advisable to take the vehicle to an approved dealer as soon as possible to check the brake system and refill it if necessary.

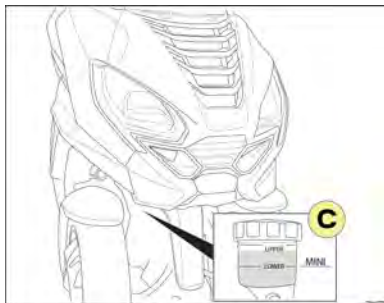

If the fluid level falls significantly, get the circuit checked straightaway by a registered dealer.

Brake fluid	DOT 5.1
-------------	---------

## Battery



Make sure you check that the battery is disconnected before performing any operations on it.

Battery power leads must never be disconnected while the engine is running.

To avoid damage to the electronic circuit, do not charge the battery if it is connected to the vehicle.

To avoid any risk of destruction of an electrical component, you are strongly advised not to use a booster charger to start the vehicle.



The sulphuric acid contained in the battery electrolyte can cause serious burns.

Avoid all contact with the skin, eyes or clothing and always protect your eyes when working near the battery.

In case of leakage, you are advised to consult a registered dealer who is equipped to replace and dispose of batteries without endangering nature and the environment.



A battery produces explosive gases. Keep the battery away from sparks, flames, cigarettes, etc..

It should be charged in a well-ventilated area.

## Extended periods of immobilisation and storage



If the vehicle is not used for an extended period, the battery will slowly discharge naturally or due to its electronics or certain accessories and must thus be regularly charged.

GB

**If the vehicle is not used for a period of 1 month or longer, the battery charge must be preserved:**

- Using a maintenance charger (if the vehicle is not used for a long period).
- If not, by disconnecting it from the vehicle (if the vehicle is not used for a period of less than 2 months).



If these recommendations are not followed, the battery may go into deep discharge. In this case the manufacturer's warranty will be void.

### Removal of the battery

Remove the 2 screws from the battery cover using the male wrench attached under the saddle.

Disconnect the battery in the following order:

1. The negative terminal.
2. The positive terminal.

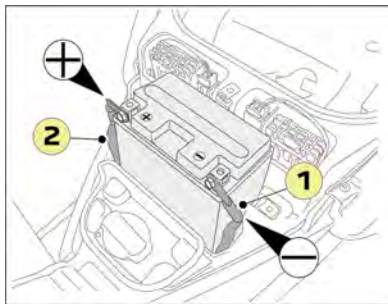

### Battery charge

The battery must be charged in a well-ventilated area with a suitable charger that can feed a tenth of the battery capacity to avoid premature destruction. You are therefore advised to go to a registered dealer to carry out this operation.

Batteries contain sulphuric acid. Do not allow it to come into contact with skin or eyes. While the

battery is charging, it can release explosive gases. Keep sources of sparks, flames and incandescent products away from it.



To avoid any risk of damaging the electronic circuit, do not charge the battery if it is connected to the vehicle with the contact in the "ON" position.

### Maintenance-free batteries

A maintenance-free battery must never be opened for topping up.

- Disconnect and remove the battery.
- Charge the battery to 100% beforehand.
- Use a maintenance charger or charge monthly.
- Before restarting, the battery must be charged to 100%.

### Installing the battery

Connect the battery in the following order:

1. The positive terminal.
2. The negative terminal.

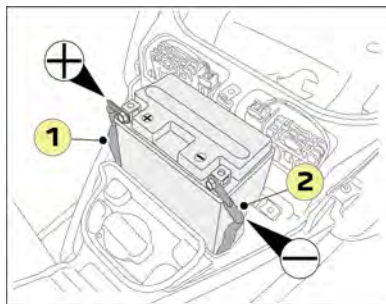

### Fuses

The electrical system is protected by fuses placed near the battery (fuses from F1 to F12).

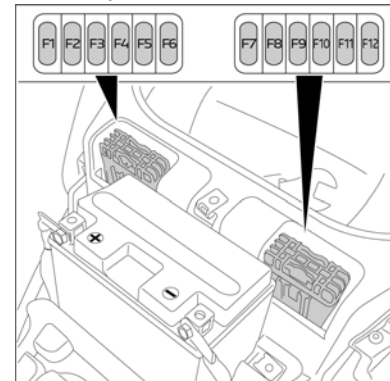

If a fuse often blows this is usually a sign of a short circuit in the electrical circuit. You are advised to have the system checked by a registered dealer. Find the faulty fuse by looking at the condition of its filament.

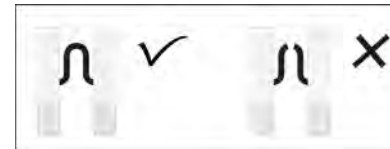

Before changing a fuse, you must find the reason for the fault and correct it. Always replace the faulty fuse with a fuse of the same rating.

Fuse allocation	
F1 10A	OBD socket
F2 3A	Instrument panel
F3 40A	General supply Battery charging
F4 40A	ABS System
F5 10A	Injection system Starter motor relay
F6 10A	Lighting
F7 10A	General supply
F8 10A	Rotating knob
F9 20A	anti-tilting System
F10 3A	Connectivity
F11 3A	12V accessory socket
F12 10A	General supply Equipments

## BULB REPLACEMENT



You are advised to contact a registered dealer to have this operation carried out.

### Number plate light bulb

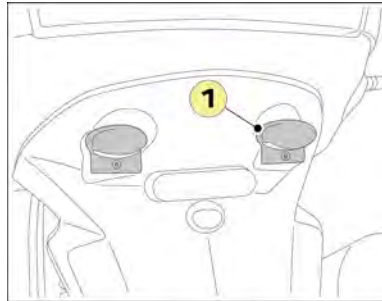

- Remove the lamp lens (1).

Number plate light bulb	12V - 5W
-------------------------	----------

## HEADLIGHT ADJUSTMENT



You are advised to contact a registered dealer to have this operation carried out.



To facilitate access to the setting screws, place the vehicle on the central stand on flat ground and deactivate the anti-tilting system.

The headlights are adjusted using one setting screw per headlight.

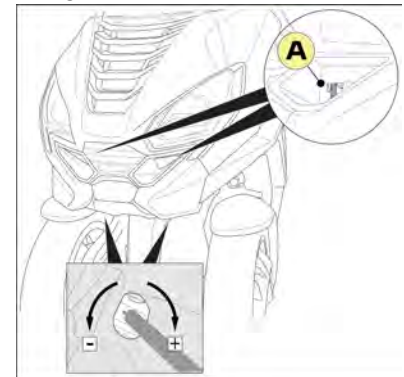

Insert the screwdriver under the vehicle and place the end in the guide (A).



Use a cross-tip screwdriver:  
PH2. 2 x 125



Before taking the vehicle off the stand activate the anti-tilting system to avoid it falling over.

GB

GB



Peugeot Motocycles recommends



Quality management system certified ISO  
9001 by UTAC



**Peugeot Motocycles SA**  
**Rue du 17 Novembre**  
**F-25350 Mandeure**

Tél. +33(0)3 81 36 80 00

RCS Belfort B 875 550 667

[www.peugeot-motocycles.fr](http://www.peugeot-motocycles.fr)  
[www.peugeot-motocycles.com](http://www.peugeot-motocycles.com)

**0 800 007 216** Service & appel  
gratuits

Dans un souci constant d'amélioration Peugeot Motocycles se réserve le droit de supprimer, modifier ou ajouter toutes références citées.  
DQ/APV du 02/2024 (photos non contractuelles).





# PEUGEOT MOTOCYCLES



GUIDE D'UTILISATION EN LIGNE  
ONLINE USER'S GUIDE

i-Connect® : application Peugeot Motocycles disponible sur

