



BY  PEUGEOT
MOTOCYCLES



KISBEE
KEEP IT SIMPLE.

S

KISBEE S
KISBEE S NAKED



LIVRET DE BIENVENUE & D'ENTRETIEN
WELCOME & MAINTENANCE BOOKLET



Bienvenue

FR

Welcome

GB

Herzlich willkommen

DE

Benvenuto

IT

Bienvenidos

ES

Welkom

NL

Καλώς ήρθατε

GR

Välkommen

SE

Bem-vindo

PT

Tervetuloa

FI

Witamy

PL

TABLE OF CONTENTS

Pre-delivery inspection.....	1
Information.....	2
Diagnostic and Personal data.....	2
Manufacturer's warranty.....	3
Important.....	6
Products to use.....	6
Maintenance advice.....	6
Cleaning the vehicle.....	6
Environment / Recyclable.....	7
Extended periods of immobilisation and storage.....	7
Quick-start guide.....	8
Starting and driving.....	8
Controls.....	8
Instruments.....	10
Instrument panel Kisbee.....	10
Instrument panel Streetzone.....	10
Equipments.....	11
Utility hanger.....	11
Advice.....	11
Fuel supply.....	11
Checking the engine oil level.....	11
Periodic servicing.....	12
Service schedule.....	13



GB

MEMORANDUM

Name:
.....
First name:
.....
Address:
.....
Post code:
.....
Town:
.....
Telephone number:
.....
Model:
.....
Colour:
.....
Engine no.:
.....

PRE-DELIVERY INSPECTION

VIN: VGA

The dealer must carry out the pre-delivery inspection and supply the preparation sheet for the delivered vehicle.

Inspection on delivery

Customer signature

I have inspected the appearance of the vehicle and signed the pre-delivery preparation sheet for my vehicle, I did not notice any anomaly. I have been informed that it is important to read the user manual and maintenance book.

Date:

Customer signature:

Dealer signature

I confirm that the vehicle identified above has undergone preparation and a pre-delivery inspection as specified by PEUGEOT MOTOCYCLES. I have supplied the customer with the user manual and maintenance book. I have explained how to operate the machine's controls and emphasised that it is important to consult the user manual and PEUGEOT MOTOCYCLES warranty conditions.

Date:

Dealer signature:

INFORMATION

You have just bought a Peugeot vehicle. We would like to thank you for purchasing one of our products.

Your vehicle is built to last but this does not mean that it does not require a minimum amount of maintenance.

Your authorised dealer is familiar with all the vehicle's characteristics and has genuine spare parts and specific tools. He can advise you and service your vehicle in the best conditions according to the established service schedule to ensure that you can enjoy driving it in complete safety.

This manual must be considered as an integral part of the vehicle and must remain with it even if the vehicle is sold on.

It also describes a selection of your vehicle's most common functions.

However, we advise you to read the entire user manual, which is available in digital format at the following address:

<https://www.peugeot-motocycles.fr/documentation>

Scan this QR code for direct access:









In particular, you will find the safety instructions, warnings, important notes and comments in it.

PEUGEOT MOTOCYCLES is constantly improving its vehicles. It therefore reserves the right to remove, modify or add any reference mentioned

The only authentic documents are those available online at the above address.

The following symbols mean:

	You are advised to read the full version of the user manual.
	Operation that can be dangerous for people.
	Operation that can be hazardous to the vehicle.
	Gives key information concerning operation of the vehicle.
	An asterisk indicates equipment depending on the version.
	The product pollutes. Do not dispose of it in the environment.

DIAGNOSTIC AND PERSONAL DATA

When diagnostic tools are connected to your vehicle, they collect data. This data includes your vehicle's identification number (VIN).

For further information on your rights or the way PEUGEOT MOTOCYCLES processes data, please refer to our privacy policy at the following address:

<https://peugeot-motocycles.com/fr/mentions-legales/>

Or contact us at:

dpo@peugeotmotocycles.com

MANUFACTURER'S WARRANTY

(March 2022 edition)

The manufacturer of your vehicle, PEUGEOT MOTOCYCLES, which has its head office at rue du 17 novembre - 25350 Mandeure (France), hereinafter PEUGEOT MOTOCYCLES, offers you a commercial warranty on your new combustion engine or electric vehicle against any material or construction defects.

These manufacturer warranty terms are also available on the website.

<https://www.peugeot-motocycles.fr/documentation>

Duration of the warranty

Unless specific contrary provisions have been brought to your attention (warranty extension, fleet agreement, etc.), PEUGEOT MOTOCYCLES grants your vehicle a manufacturer's warranty for a period of:

- 24 months for private use, unlimited mileage;
- 24 months for professional use, limited to 20 000 km (<50cc, cat. L1e & L2e) or 30 000 km (>50cc, cat. L3e & L5e).



The term 'trader' is defined as "any public or private natural or legal person acting for purposes relating to their trading, business, craft, professional or agricultural activity, even when they act in the name or on behalf of another trader".

This warranty starts from the first time the vehicle is registered and applies to your vehicle with the exception of:

- The electric vehicle traction battery for which the current warranty is 24 months or 20 000 km, whichever is reached first, subject to the maintenance charges having been done regularly in accordance with the instructions in the PEUGEOT MOTOCYCLES maintenance manual;
- The electric vehicle traction battery for which the stated nominal capacity has declined by less than or equal to 25%, measured by a PEUGEOT MOTOCYCLES network technician during the warranty period. Due to the inherent chemistry of the battery, a decline in battery capacity (and therefore the vehicle's autonomy) may be observed over time, as the vehicle is used and according to the storage conditions;
- The combustion engine vehicle battery for which this warranty is six months subject to a minimum mileage of 200 km per month;
- The stand and the saddle, for which the warranty period is six months.

Scope of the manufacturer's warranty

With the exception of the restrictions stated below, this contractual warranty covers the repair or replacement of parts found to be faulty by PEUGEOT MOTOCYCLES or its representative and any ensuing labour costs.

It should be noted that:

- The repair or replacement of parts under this manufacturer's warranty does not extend the duration thereof. The warranty covering replacement parts fitted to your vehicle expires on the same date as your vehicle warranty;
- The faulty parts replaced under the warranty will be kept and become the property of PEUGEOT MOTOCYCLES.

Conditions of application of the commercial warranty

For optimal cover for work to be carried out on your vehicle under this commercial warranty, PEUGEOT MOTOCYCLES recommends that you exclusively entrust said work to a workshop within the authorised network.

If your vehicle is sold on, its successive owners shall benefit from the warranty until its date of expiry on condition that the application conditions of the warranty have been satisfied by each of them. For this purpose, you undertake to transmit the warranty application terms to the buyer of your vehicle, along with evidence of maintenance operations performed.

GB

The warranty applies on condition that:

- The first "warranty" service has been carried out and the vehicle has been regularly serviced in line with the instructions of the PEUGEOT MOTOCYCLES maintenance manual, and you can provide proof of this (service monitoring sheet, invoices, etc.). A tolerance of 100 km (or 1 month) for the annual maintenance) is permitted in relation to the mileage specified in the maintenance schedule;
- The enhanced maintenance schedule is applied for professional use and, where necessary, for private use;
- Original parts have not been replaced with other components that have not been approved by PEUGEOT MOTOCYCLES and/or the assembly of which does not comply with good practices or the recommendations of PEUGEOT MOTOCYCLES (including, but not limited to, exhaust pipe, cylinder, piston, spark plug and the intake silencer on combustion vehicles, fuses, traction battery modules and the traction battery charger on electric vehicles, etc.);
- The vehicle has not been modified, transformed or equipped with accessories that have not been approved by PEUGEOT MOTOCYCLES (including, but not limited to, additional charger for electric vehicles, alarms, radio, headlights, luggage carriers, boosters, etc.);
- The vehicle has not been used for sports competitions;

The warranty does not cover:

- Maintenance operations (such as, but not limited to: oil change, lubrication, adjustment, cleaning, tensioning, etc.) and servicing listed in the PEUGEOT MOTOCYCLES service schedule and required for your vehicle to operate properly;
- The replacement of parts subject to normal wear linked to use of the vehicle, its mileage, its geographical and climatic environment and their non-reusable fastening parts (such as, but not limited to: self-locking nuts, etc.), if this replacement is not due to a manufacturing defect. This includes but is not limited to the following parts;
 - Drive pulley and driven pulley and belt, clutch, rollers, mobile flange, guides, chain, pinion, rear cog;
 - Bearings (wheels, rods, steering, engine, etc.);
 - Bulb, fuse, tyre, brake linings and pads, brake disc, cables and cable controls, spark plug and spark suppressor;
 - Shock absorbers (hydraulic, gas, single spring, elastomer), air filter, entire intake silencer, fuel filter, oil filter, cylinder, piston and piston segments;
 - Exhaust on combustion engine (except unwelded internal elements);
 - Liquids and products (grease, hydraulic fluid, brake fluid, gearbox oil, engine oil and coolant, etc.);
- Repairs resulting from the use of fuels, lubricants or grease other than those recommended by PEUGEOT MOTOCYCLES;
- Repairs resulting from negligence, abnormal use, driving on an impassable or damaged road, failure to follow the advice given in the PEUGEOT MOTOCYCLES service schedule or the user manual, overloading, even temporary, or the driver's lack of experience;

- Repairs due to an accident, theft, fire or natural causes (including, but not limited to hail, flooding, etc.);
- Repairs resulting from lack of vehicle cleanliness;
- Repairs resulting from long storage periods under unsuitable conditions;
- Corrosion or surface oxidation on the chassis, the screws, and, more generally, on all other metal parts, whether treated or not on combustion or electric vehicles (however, pitting corrosion is covered for a period of 24 months);
- The meter or optics for which the presence of steam does not alter information readability or lighting efficiency;
- Noises and vibrations which have no influence on the reliability, safety and road behaviour of the vehicle;
- Any other expenses not specifically included in this warranty or the legal compliance warranty or the legal warranty against hidden defects, such as, but not limited to: costs due to the vehicle being immobilised, loss of use or business, etc.

Geographical scope of application

The warranty is applicable in the countries or territories where the vehicle is marketed by the approved PEUGEOT MOTOCYCLES network (in particular, France, Germany, Italy, Spain) a list of which can be consulted on the manufacturer's website:

<http://www.peugeot-motocycles.com>

The vehicle is intended exclusively for sale and use in the above-mentioned countries and territories excluding all other countries or territories, where the applicable standards may be different to those in the above-mentioned countries and territories, such as, but not limited to, the United States of America, etc. Use of the vehicle in these excluded countries or territories is under the user's entire responsibility and excludes the application of this warranty as well as the vehicle manufacturer's responsibility for any reason whatsoever.

In some countries, especially in European Union Member States, the consumer has rights under the applicable national legislation. These rights are not affected by the warranty as defined above.

IMPORTANT**Products to use**

Fuel	Exclusively: Unleaded E5 or E10
	
4 stroke engine oil	SAE 5W40 100% synthetic Minimum grade API SN
Relay box oil	SAE 80W90 API GL4
Brake fluid	Brake fluid DOT 4
Grease	High-temperature grease Multi-use grease
Fork oil	10W hydraulic oil

Maintenance advice

Ensure that the servicing schedule for your vehicle is strictly followed to maintain your contractual warranty rights.

A table of inspections for the maintenance schedule is inserted into the maintenance booklet. The registered dealer must add his stamp, the date of servicing and the number of kilometres the vehicle has covered.

In order to maintain maximum safety and reliability of your vehicle, you are advised to have maintenance and repairs carried out by a registered dealer who has the necessary technical training, specific tools and spare parts.

After an accident, it is recommended to have the vehicle inspected and repaired by a registered dealer.

Cleaning the vehicle

The bodywork is made of plastic parts that can be painted or are shiny. Do not use solvents or cleaning products that are too corrosive.



Do not use high pressure cleaners which may cause water to infiltrate the following parts: seals, bearings and hinges, electrical components such as connectors, contactors and lighting.

Wash the bodywork with soapy water and rinse with generous amounts of clear water.

The vehicle can be dried with a chamois leather. After washing the vehicle, brake several times at low speed to dry out the brakes.



The vehicle should be washed in a place equipped for wastewater collection.

Certain silicon-based products can alter the quality of the paintwork.

In case of need or doubt, a registered dealer can advise you on using cleaning products or restoring scratched bodywork.

Environment / Recyclable

Worn parts replaced during routine maintenance (mechanical parts, battery, etc.) must be disposed of with specialised bodies.

At the end of its life, the vehicle must be taken to an authorised centre for recycling.

In all cases, comply with the local laws.



Batteries contain harmful substances. They must be disposed of according to the legal requirements and must under no circumstances be thrown away in the household waste.

Extended periods of immobilisation and storage

If the vehicle has to be immobilised for more than 1 month, you are advised to carry out the following operations:

Battery



If the vehicle is not used for an extended period, the battery will slowly discharge naturally or due to its electronics or certain accessories and must thus be regularly charged.

- Charge the battery to 100% beforehand (The battery's maximum charging current is equal to 1 tenth of its capacity).
- Use a maintenance charger or charge monthly.
- Before restarting, the battery must be charged to 100%.



If these recommendations are not followed, the battery may go into deep discharge. In this case the manufacturer's warranty will be void.

Machine

- Empty the fuel tank to avoid fuel build-ups.
- Spray a lubricant onto the metal parts of the vehicle to avoid oxidation.
- Store the vehicle in a dry place.

Re-starting your vehicle

You are advised to have the vehicle checked over by a registered dealer if it has been immobilized for an extended period.

QUICK-START GUIDE

Starting and driving

Key-operated ignition switch functions

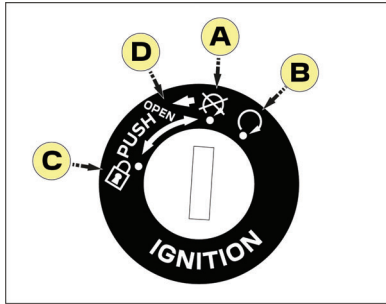

A. Engine off position

The engine is off. Power to the electrical circuit is off. The key can be removed.

B. On position

Power to the electrical circuit is on. The engine can be started. The key cannot be removed.

C. Steering unlocked

Power to the electrical circuit is off.

- Turn the handlebar to the left.
- Turn the key to the locked position to lock the steering. The key can be removed.

D. Opening the saddle

Turning the key to this position enables the saddle to be opened using a cable system.

Starting the engine

For greater safety, place the vehicle on its central stand before starting the engine.



Ensure that the switch under the saddle is in position UNLOCK*.

- Turn the ignition key to "ON".
- Ensure that the throttle is in the OFF position.
- Press one of the brake levers while pressing the starter button. Do not press the starter for more than 10 seconds.
- Release the starter button as soon as the engine starts.



If the engine does not start, release the starter button and the brake lever, wait a few seconds and try again.

Driving

The vehicle is on its stand with the engine running.

- Squeeze the brake lever with your left hand, grip the grab handle with your right hand and push the vehicle forwards to fold up the central stand.
- Sit on the vehicle.
- Release the left brake and turn the throttle slowly with your right hand to start moving.

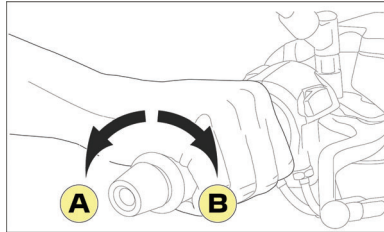

To accelerate, turn the throttle towards (A). To slow down, turn the throttle towards (B).

Braking

The right lever controls the front brake and the left lever controls the rear brake

Use of the brakes

For good braking, it is very important to coordinate the following actions:

- Allow the throttle handle to return quickly.
- Operate the left and right brake levers simultaneously and slowly increase the pressure.

Stopping the vehicle and parking

Stop the vehicle and switch of the engine by turning the rotating knob to "OFF".

The vehicle should be preferably parked on flat ground.

- Either on the middle stand.
- Or on the lateral stand.



The steering must be locked every time you park.

Controls

Left controls

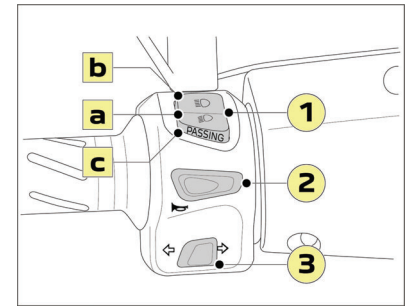

1. Dipped lights/Headlights switch

The dipped lights/headlights switch has 3 functions:

- A. Dip beam.
- B. High beam.
- C. Flashing the lights (Passing).

2. Horn switch

3. Indicators switch

Right controls

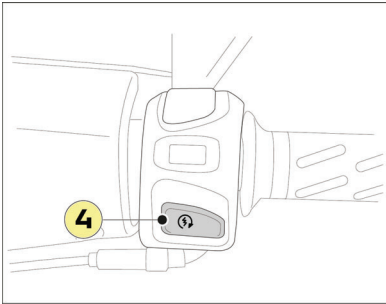

4. Starter switch.



Refer to the online user manual for further information.

INSTRUMENTS



Refer to the online user manual for further information.

GB

Instrument panel Kisbee

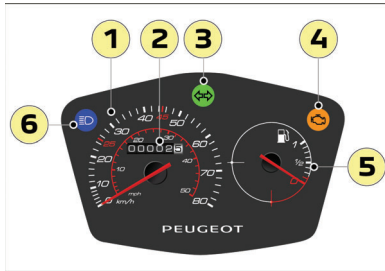

1. Speedometer.

- Double-scale speedometer showing kilometers and miles.

2. Milometer.

3. Direction indicator warning light.



If the warning light flashes quickly, there is a fault in the direction indicators.

4. Malfunction warning light for the antipollution system / Engine self-diagnostic.



Fixed / Flashing.
The anti-pollution system is faulty.



You are advised to have the vehicle checked by an authorised dealer.

5. Fuel gauge.

6. Main beam control.

Instrument panel Streetzone

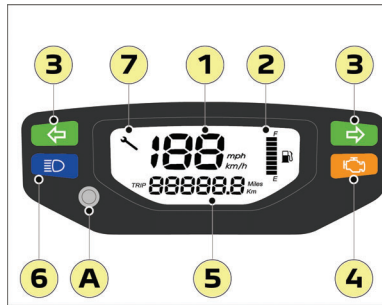

1. Speedometer.

2. Fuel gauge / Fuel reserve gauge.

The fuel reserve gauge corresponds to the last two segments which indicate two reserve levels.

3. Right-Left indicator warning light.

4. Malfunction warning light for the antipollution system / Engine self-diagnostic.



Fixed / Flashing.
The anti-pollution system is faulty.



You are advised to have the vehicle checked by an authorised dealer.

5. Milometer / Tripmeter (TRIP).

Changing from the total distance display to the daily distance display

- With the ignition on, switching from the total distance display to the daily tripmeter and vice-versa is done by briefly pressing the control button (A).

Resetting the tripmeter

- The daily counter is reset by pressing more than 3 seconds on the control button (A).

6. Main beam control.

7. Maintenance indicator.

A. Display control button.

EQUIPMENTS



The user manual describes other equipment.

Utility hanger

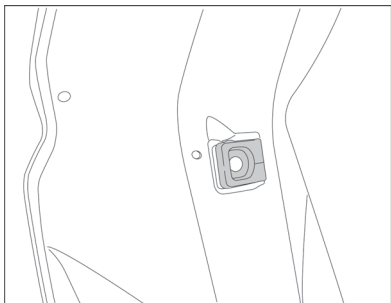

The utility hanger is located on the rear shield panel. It can be used to attach a maximum load of 2.5 kg.

ADVICE

Fuel supply

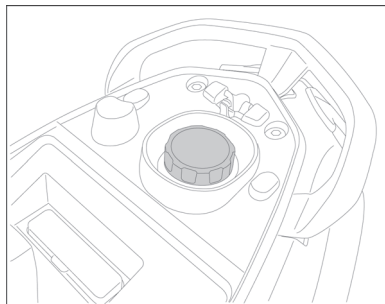

The fuel tank is located under the saddle.

- Place the vehicle on the central stand.
- When filling up with fuel, ensure the end of the nozzle is correctly inserted into the filling orifice on the fuel tank.



Do not fill the fuel tank to excess: The fuel may expand due to the engine heat or heat from the sun and overflow.

Checking the engine oil level



Check the oil level every 1000km / 600Mi or before a long journey.

- To correctly measure the oil level, place the vehicle on the centre stand on flat ground.
- Start the engine, let it run for a few minutes and then stop it.
- After switching off the engine, wait for 5 minutes to allow the engine oil time to return to the oil sump.
- Remove the oil filler cap/gauge (1).

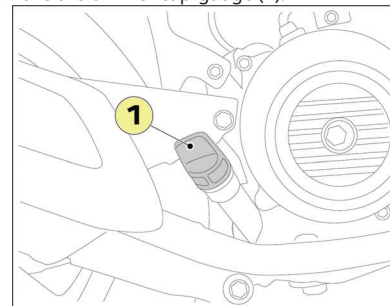

- Wipe the filler cap/gauge using a clean cloth and reinsert it into the filler hole without screwing it up.

GB

- Remove the filler cap/gauge and check the oil level.
- The oil level shall be between the minimum (A) and maximum (B) level marks without exceeding the latter.

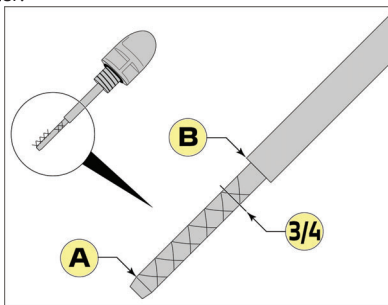

- If the oil level is close to the minimum mark or lower, you are advised to immediately top up the level to 3/4 in small amounts using the oil recommended by the manufacturer.



Too much oil will noticeably restrict the vehicle's performance.

PERIODIC SERVICING

Special important points:

- Compliance with the servicing schedule in light of the conditions of use will help keep your vehicle running smoothly over time and preserve its qualities, while being covered by the warranty. We recommend that you entrust these operations to an authorised Peugeot Motorcycles dealer who has been trained by the manufacturer and has suitable tools.
- There is no need for an annual test if a periodic test has been conducted during the year.
- From 25000 km (15600 mi), servicing must be performed by repeating operations from 5000 km (3100 mi).
- Clean or replace the air filter (engine/transmission) more often if the vehicle is used in particularly dusty or humid areas.

Heavy duty servicing / Harsh conditions of use:

The servicing of certain components (oil, air filter, etc. see maintenance schedule) must be performed regularly if the vehicle is used in one or more of the following conditions:

Humid, dusty, high heat area, predominantly urban use, at temperatures frequently dropping below -5°C, Repeated short or door-to-door trips with a cold engine at a low temperature, etc.

Vehicles used for commercial purposes (home deliveries, couriers, etc.) should, in particular, be subject to heavy duty servicing (The service mileage should be halved).

Care / Cleanliness:

In light of the design and aesthetic appeal of a two-wheeled vehicle, numerous components are exposed to the elements. This vulnerability may result in functional or cosmetic damage (corrosion, etc.), even on high-quality parts. This is why proper regular servicing helps not only preserve its appearance, smooth running and your enjoyment; it is also essential to maintain your Warranty rights.

SERVICE SCHEDULE

Servicing must be performed by a PEUGEOT MOTOCYCLES registered representative.

Operations to be carried out	500km 300mi Or 1 months	5000km 3100mi	10000km 6200mi	15000km 9300mi	20000km 12400mi	Annual maintenance / Heavy duty servicing
Engine						
Engine oil	R	R Every 5000 km (2500 km if harsh use servicing)				R
Oil filter (Screen)	C	C	C	C	C	C
Valve clearances	I		I		I	
Spark plug			R		R	
Intake air filter		R Every 10000 km (5000 km if harsh use servicing)				
Intake silencer drain		C	C	C	C	C
Drive pulley / Flange wear			I		R	
Drive pulley rollers and guides			R		R	
Transmission belt			R		R	
Driven pulley caged needle bearing			L			
Clutch lining wear			I			
Driven pulley			I		R	
Transmission fluid	R		R		R	
Kick starter mechanism		L	L	L	L	L
Petrol filter		I	R	I	R	
Petrol pipe: No leaks or cracks	I	I	I	I	I	I
Canister unit, canister valves and hoses		I	I	I	I	
Inlet canister valve		I	R	I	R	
I: Inspect, clean, adjust, replace if necessary. C: Clean, replace if necessary. R: Change. L: Lubricate, oil						

GB

Operations to be carried out	500km 300mi Or 1 months	5000km 3100mi	10000km 6200mi	15000km 9300mi	20000km 12400mi	Annual maintenance / Heavy duty servicing
Cycle part						
Steering: No sticking point / No play	I	I	I	I	I	I
Wheels: Condition and runout / No play	I	I	I	I	I	
Tyres: No cracks, wear and pressure	I	I	I	I	I	I
Fork / Front suspension: Condition, operation and no leakage	I	I	I	I	I	I
Fork oil ^a					R	
Rear suspension: Condition, operation and no leakage	I	I	I	I	R	I
Throttle control: Operation, play and lubrication	I	I + L	I + L	I + L	I + L	I
Moving parts and cables		L	L	L	L	L
Kickstands: Operation and lubrication		I + L	I + L	I + L	I + L	I + L
Tightness of nuts and bolts	I	I	I	I	I	I
Braking system						
Brake fluid level / No leakage	I	I	I	I	I	I
Brake fluid	R Once every 2 years					
Brake calliper: Cleanliness, Guide pins, Functioning			I + L		I + L	I + L
Brake pad wear		I	I	I	I	I
Brake disk wear		I	I	I	I	I
Brake hose: No leaks or cracks		I	I	I	I	I
Cable-operated brake control: Condition and lubrication		I + L	I + L	I + L	I + L	I + L
Brake lining wear		I	I	I	I	I
Brake levers		L	L	L	L	L
I: Inspect, clean, adjust, replace if necessary. C: Clean, replace if necessary. R: Change. L: Lubricate, oil						

^a Depending on model

Operations to be carried out	500km 300mi Or 1 months	5000km 3100mi	10000km 6200mi	15000km 9300mi	20000km 12400mi	Annual maintenance / Heavy duty servicing
Electrical equipment						
Lighting and signalling	I	I	I	I	I	I
Headlight height adjustment	I	I	I	I	I	
Brake light switches	I	I	I	I	I	I
Battery: Charge level and no leakage	I	I	I	I	I	I
Miscellaneous						
Processors: Reading of fault codes and update	I	I	I	I	I	I
Overall operation: Road test	I	I	I	I	I	I
			I: Inspect, clean, adjust, replace if necessary. R: Change.		C: Clean, replace if necessary. L: Lubricate, oil	
Servicing time in tenths of an hour (0.5 h = 30 mn)						
Reception and Treatment	0.1	0.1	0.1	0.1	0.1	0.1
Kisbee S / Kisbee S naked	1.4	0.9	2.5	0.9	3.2	0.5
Maintenance times are indicative. They do not take into account the replacement of wear parts.						

_____ km
 _____ *mi*
 _____ / _____ / _____



_____ km
 _____ *mi*
 _____ / _____ / _____



_____ km
 _____ *mi*
 _____ / _____ / _____



_____ km
 _____ *mi*
 _____ / _____ / _____



_____ km
 _____ *mi*
 _____ / _____ / _____



_____ km
 _____ *mi*
 _____ / _____ / _____



_____ km
 _____ *mi*
 _____ / _____ / _____



_____ km
 _____ *mi*
 _____ / _____ / _____



_____ km
 _____ *mi*
 _____ / _____ / _____



FR

GB

DE

IT

ES

NL

GR

SE

PT

FI

DK

----- km

----- *mi*



----- / ----- /-----

----- km

----- *mi*



----- / ----- /-----

----- km

----- *mi*



----- / ----- /-----

----- km

----- *mi*



----- / ----- /-----

----- km

----- *mi*



----- / ----- /-----

----- km

----- *mi*



----- / ----- /-----

----- km

----- *mi*



----- / ----- /-----

----- km

----- *mi*



----- / ----- /-----

----- km

----- *mi*



----- / ----- /-----

<p>----- km</p> <p>----- mi</p>	
<p>----- km</p> <p>----- mi</p>	
<p>----- km</p> <p>----- mi</p>	
<p>----- km</p> <p>----- mi</p>	
<p>----- km</p> <p>----- mi</p>	
<p>----- km</p> <p>----- mi</p>	
<p>----- km</p> <p>----- mi</p>	
<p>----- km</p> <p>----- mi</p>	
<p>----- km</p> <p>----- mi</p>	

- FR
- GB
- DE
- IT
- ES
- NL
- GR
- SE
- PT
- FI
- DK

FR

_____ km



_____ mi

GB

_____ km



_____ mi

DE

_____ km



_____ mi

IT

_____ km



_____ mi

ES

_____ km



_____ mi

NL

_____ km



_____ mi

GR

_____ km



_____ mi

SE

_____ km



_____ mi

PT

_____ km



_____ mi

FI

DK

Peugeot Motocycles recommends



Quality management system certified ISO
9001 by UTAC



Peugeot Motocycles SA
Rue du 17 Novembre
F-25350 Mandeuire

Tél. +33(0)3 81 36 80 00

RCS Belfort B 875 550 667

www.peugeot-motocycles.fr
www.peugeot-motocycles.com

0 800 007 216

Service & appel
gratuits

Dans un souci constant d'amélioration Peugeot Motocycles se réserve le droit de supprimer, modifier ou ajouter toutes références citées.
DQ/APV du 02/2024 (photos non contractuelles).



KISBEE
KEEP IT SIMPLE.

1140378000 07/24 .v1

KISBEE



GUIDE D'UTILISATION EN LIGNE
ONLINE USER'S GUIDE